

IWAKI

Pneumatic Drive Bellows Pump

CFD-1T-B

Instruction Manual

⚠ Read this manual before use of product

Thank you for selecting an Iwaki's CFD-1T-B Pneumatic Drive Bellows Pump. This instruction manual deals with “*Safety instructions*”, “*Outline*”, “*Installation*”, “*Operation*” and “*Maintenance*” sections. Please read through this manual carefully to ensure the optimum performance, safety and service of your pump.

Contents

Important instructions	1
Safety instructions	2
<i>Outline</i>	
1. Unpacking & Inspection	6
2. Operating principle	6
3. Specification.....	7
4. Outer dimension.....	8
5. Part names & Structure.....	9
6. Overview.....	10
<i>Installation</i>	
1. Before installation	12
2. Installation/Piping/Wiring	14
<i>Operation</i>	
1. Before operation	24
2. Operation.....	24
3. Adjustment of liquid volume per shot	25
4. Check items.....	27
<i>Maintenance</i>	
1. Troubleshooting.....	29
2. Maintenance & Inspection	30
3. Wear parts	30



This instruction manual should be kept on hand by the end user for quick reference.

Contact us or your nearest dealer if you have any questions.

Important instructions

For the Safe and Correct Handling of the Pump

- "Safety Instruction" section deals with important details about handling of the product. Before use, read this section carefully for the prevention of personal injury or property damage.
- Observe the instructions accompanied with "WARNING" or "CAUTION" in this manual. These instructions are very important for protecting users from dangerous situations.
- The symbols on this instruction manual have the following meanings:

 WARNING	Nonobservance or misapplication of "Warning" sections could lead to a serious accident which may result in death.
 CAUTION	Nonobservance or misapplication of "Caution" sections could lead to a personal injury or property damage.

Types of Symbols



Indicates that "Warning" or "Caution" must be exercised. Inside this triangle, a concrete and practical image provided as a warning or caution message is depicted.



Indicates a prohibited action or procedure. Inside or near this circle, a concrete and practical image of the activity to be avoided is depicted.



Indicates an important action or procedure which must be performed or carried out without failure. Failure to follow the instructions herein can lead to malfunction or damage to the pump.

For exportation

Technology related to the use of goods in this instruction manual falls in the category of technology contained in the Foreign Exchange Order Attachment, which includes complementary export control of technology. Please be reminded that export license, which is issued by the Ministry of Economy, Trade, and Industry could be required, when this is exported or provided to someone even in Japan.

Safety instructions

WARNING

- **Wear protective clothing**

Always wear protective clothing such as safety goggles, protective gloves, a cap, a gas mask and a face guard during pipework or dismantlement. Flush the inside of the pump with pure water beforehand.



- **Ventilation**

Poisoning may result when handling volatile fluid. Keep good ventilation in your operating site.



- **Explosive or flammable liquid**

Risk of fire or explosion. Do not use explosive or flammable liquid. The proximity switches are not in explosion-proof and a spark may be caused from the electrode of the leak sensor.



Prohibited

- **Assure safety before turning on power**

Keep workers away from around the pump when turning on power. The pump doesn't have the ON-OFF switch. The pump starts as powered.



Caution

- **No modification**

Do not modify the pump. We are not responsible for any personal injury or property damage due to modification.



No Remodeling

- **For specified application only**

The use of the pump in any application other than those clearly specified may result in personal injury or property damage.



Prohibited

- **Turn off power and air supply before work**

Be sure to turn off power to stop the pump and air supply before work. Make sure no one turns on the power by mistake while working on the pump, otherwise it may result in a serious accident. If your work field is noisy or dark, let other people know about the situation by displaying a notice such as "POWER OFF (Maintenance)" near the power switch.



Power off

- **Drainage**

Do not drain chemicals directly onto the ground or a waste channel. Disposal of chemicals should be in accordance with an applicable law.



Prohibited

Safety instructions

CAUTION

- **Specified power only**

Do not apply any power other than the specified one on the nameplate. Otherwise, personal injury or property damage may result.



- **A qualified operator only**

The pump must be handled or operated by a qualified person with a full understanding of the pump. Any person who is not familiar with this product should not take part in operation or management.



- **Do not install or store the pump in the following places where...**

- Under a flammable atmosphere.
- In a dusty place.
- Under a corrosive atmosphere such as chlorine gas.



- **Pump disposal**

Dispose of any used or damaged pump in accordance with local laws and regulations (Consult a licensed industrial waste products disposing company.).



- **Returning the pump**

Drain a chemical and rinse the inside for safe transportation before return.



- **Observe the maximum stroke rate**

Operation above the maximum stroke rate of 30spm may reduce the life of bellows.



- **Observe the maximum supply air pressure**

Operation above the maximum supply air pressure of 0.3MPa may reduce the life of bellows.



- **Liquid temperature**

Observe the allowable liquid temperature range of 20 - 60°C



- **Do not touch the pump or pipe with bare hands**

The surface temperature of the pump or pipe rises high along with liquid temperature in or right after operation.



- **Do not run the pump with the following liquid**

- Liquid easily crystallizes
- Slurry
- Flammable liquid or explosive liquid



Safety instructions

CAUTION

- **Liquids to be handled with care**

- Stripper
- Solvent
- Hydrazine
- Fuming sulfuric acid



- **Static electricity**

When low electric conductivity liquids such as ultra-pure water and fluor inactive liquid (e.g. Fluorinert™) are handled, the static electricity may be generated in the pump and may cause static discharge. Take countermeasures to remove static electricity.



- **When stopping the pump**

- Before stopping the pump, release discharge pressure. Otherwise, the bellows may deform due to residual pressure.
- Do not close a discharge valve including an air-operated valve as stopping the pump. An impact pressure may deform the bellows.



- **After stopping the pump**

Do not leave the pump with any chemical in the bellows for a long period. Some chemical gas can penetrate the bellows and corrode metal parts.



- **During pump operation**

Make sure all suction and discharge valves are open.



- **Countermeasure against efflux**

Take a protective measure against the accidental efflux caused by pump or liquid line breakage.



- **Electrodes**

The electrode occasionally fails to detect leakage depending on operating conditions. Contact us for detail.



- **Ambient temperature**

Observe the allowable ambient temperature range of 10 - 40°C.



Outline

<i>1. Unpacking & Inspection</i>	<i>6</i>
<i>2. Operating principle.....</i>	<i>6</i>
<i>3. Specification</i>	<i>7</i>
<i>4. Outer dimensions.....</i>	<i>8</i>
<i>5. Part names & Structure</i>	<i>9</i>
<i>6. Overview.....</i>	<i>10</i>

Outline

1. Unpacking & Inspection

On unpacking the product, check the following points. If you find any problems, contact your nearest dealer.



1. Check the information on labels to see if the delivery is as per order.
2. Check for transit damage and loose bolts.
3. Check that all the accessories you ordered are included.

2. Operating principle

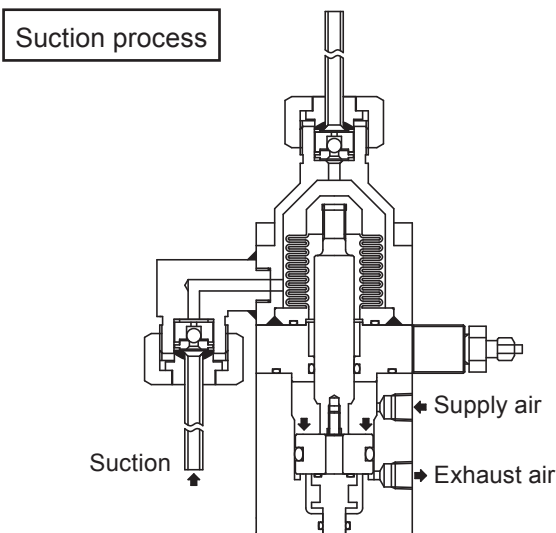

The CFD-1T-B is a pneumatic drive bellows pump with fluoroplastic wet ends that are capable of handling chemical liquid required for semiconductor processing. The piston rod in the air cylinder makes reciprocation as air is supplied and exhausted in order to expands or contracts the bellows in the pump chamber, where liquid is transferred from the inlet to outlet.

a. Suction process

The piston rod contracts to retract the bellows in order to introduce liquid into the pump chamber when air is supplied to the upper compartment divided by the piston in the air cylinder.

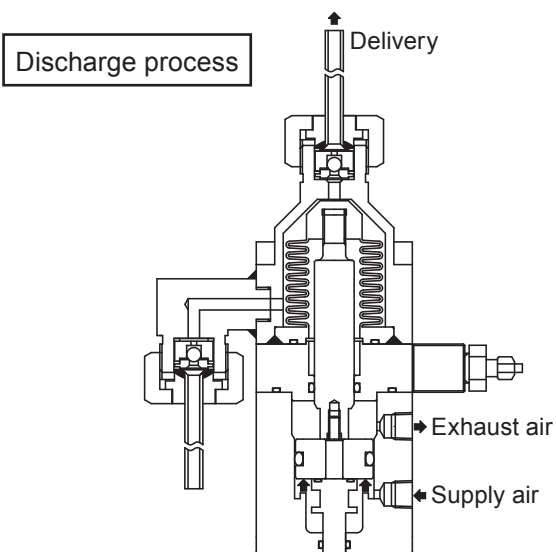

b. Discharge process

The piston rod extends to expand the bellows in order to deliver liquid from the pump chamber when air is supplied to the lower compartment divided by the piston in the air cylinder.

Outline

3. Specification

	Item	CFD-1T-B
Pump	Application	Chemical feeding
	Liquid volume per shot*1	1 mL*1
	Maximum discharge pressure	0.05MPa
	Liquid temperature range	20-60°C
	Stroke rate range	10-30spm
	Supply air pressure range	0.15-0.3MPa
	Maximum air consumption	2.5NL/min*2
	Priming lift	50cm*3
	Wet ends	PTFE, PFA, PCTFE
	Liquid line port bore	1/4" PFA tube (ø6.35 × 4.35 mm)
	Air line port bore	Rc 1/8"
	Weight	1.1kg
Photo sensor	Model	SUNX Micro Photoelectric sensor
	Power voltage	5-24VDC±10%
	Output	NPN open collector
	Allowable current	50mA or below
	Cable	5m PVC four-core cable (5.2mm outer dia.) with a 0.5-4 ring terminal

*1 The liquid volume per shot is factory default setting and is obtained in operation at 30spm and ambient temperature.

*2 The maximum air consumption is obtained in operation with the supply air pressure of 0.3MPa, the stroke rate of 30spm and the discharge pressure of 0.05MPa.

*3 The suction lift is based on pumping clean water at ambient temperature.

Outline

4. Outer dimension

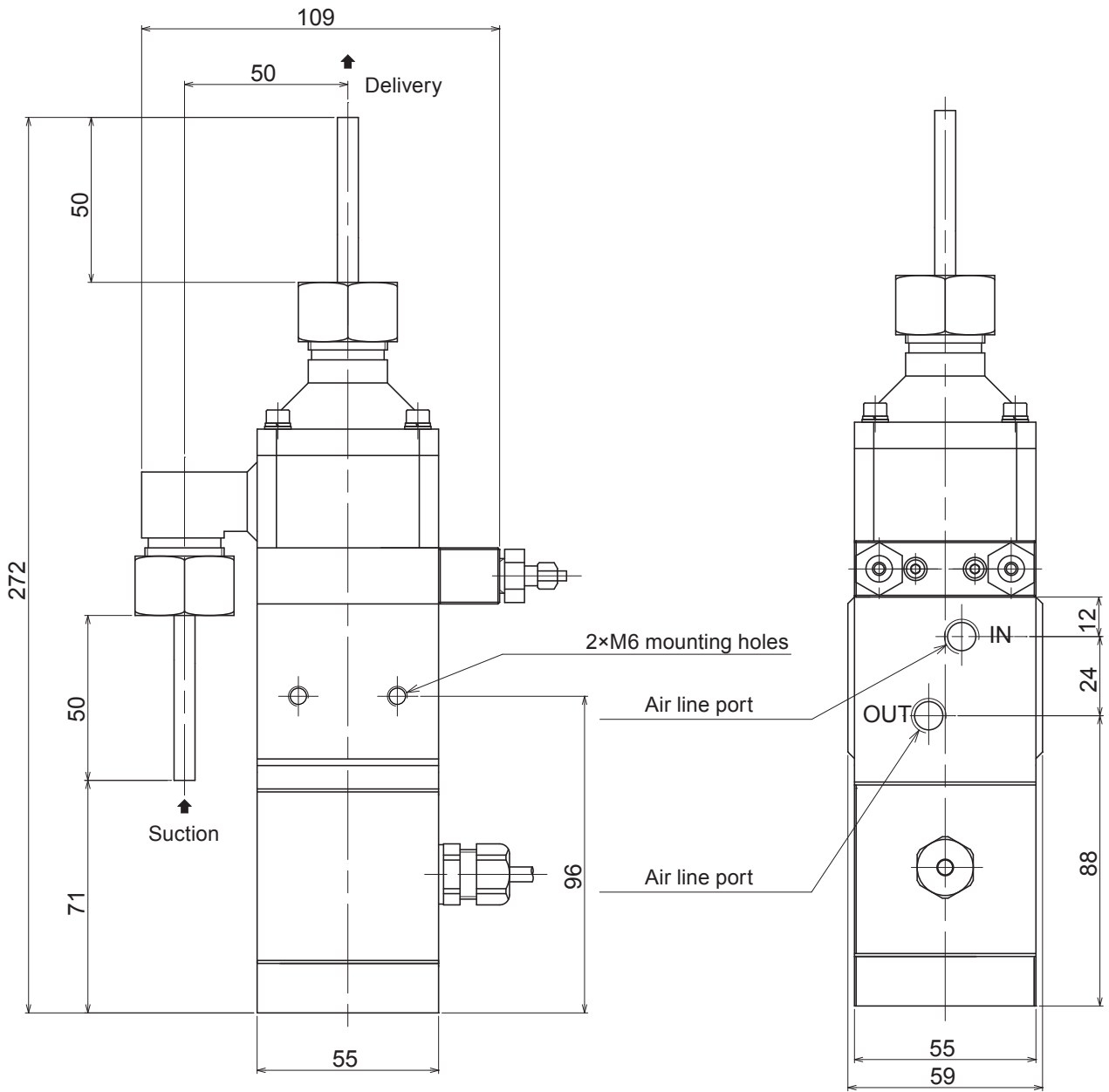

Outline

5. Part names & Structure

CFD-1T-B

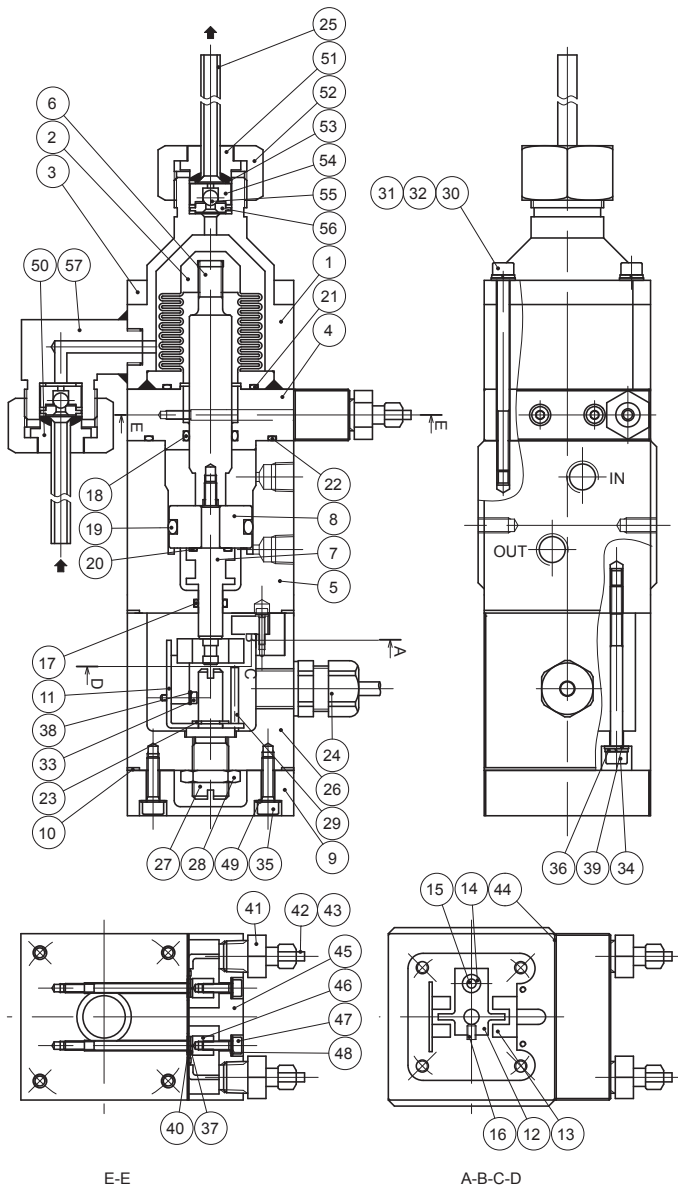

#	Part names	Qty	Materials	Remarks
1	Pump head	1	PTFE	
2	Bellows	1	PTFE	
3	Flange A	1	PVC	
4	Flange B	1	PVC	
5	Cylinder	1	PVC	
6	Piston rod A	1	SUS304	
7	Piston rod B	1	SUS304	
8	Piston	1	POM	
9	Control screw cover	1	PVC	
10	Packing A	2	PTFE	
11	Installed base	1	SUS304	
12	Guide plate	1	SUS304	
13	Photo sensor	2	-	
14	Bearing	1	Filled PTFE	
15	Parallel pin	1	STNLS STL	
16	Set screw	1	STNLS STL	
17	O ring	1	FKM	P-8
18	O ring	1	FKM	P-14
19	O ring	1	FKM	P-22A
20	O ring	1	FKM	S-9
21	O ring	1	FKM	S-26
22	O ring	1	FKM	S-40
23	Stop ring	1	STNLS STL	Nominal 6 (E type)
24	Cord ground	1	PP	SCL-6B
25	Tube	2	PFA	1/4"(ø6.35×ø4.35)
26	Control case	1	PVC	
27	Control screw	1	SUS304	
28	Nut	1	STNLS STL	M12×1.0
29	Parallel pin	1	STNLS STL	ø2.5×24
30	Hex. sock cap bolt	4	STNLS STL	M4×65 PTFE coating
31	Spring washer	4	STNLS STL	M4 PTFE coating
32	Plate washer	4	STNLS STL	M4 PTFE coating
33	Hex. sock cap bolt	4	STNLS STL	M2×10
34	Hex. sock cap bolt	4	STNLS STL	M4×55
35	Hex. sock cap bolt	4	STNLS STL	M4×15 PTFE coating
36	Spring washer	4	STNLS STL	M4
37	Spring washer	2	STNLS STL	M3
38	Spring washer	4	STNLS STL	M2
39	Plate washer	4	STNLS STL	M4
40	Plate washer	2	STNLS STL	M3
41	Male connector	2	PTFE	30-3MC2-C
42	Tube adapter	2	Silicon rubber	30-15TA
43	Sensor cord	2	PVC	AWG24 5m
44	Packing B	1	PTFE	
45	Electrode cover	1	PVC	
46	Electrode	2	SUS304	
47	Hex. sock cap bolt	2	STNLS STL	M3×10 PTFE coating
48	Plate washer	2	PTFE	M3
49	Plate washer	4	PTFE	M4
50	Suction port	1	PTFE	
51	Discharge port	1	PTFE	
52	Valve cap	2	PP	
53	Valve gasket	6	PTFE	
54	Valve guide	2	PTFE	
55	Valve ball	2	PTFE	3/16"
56	Valve seat	2	PCTFE	
57	Valve case	1	PTFE	

Outline

6. Overview

The illustration below shows a CFD-1T-B.

⚠ CAUTION

Do not wipe labels or the pump body with solvent.

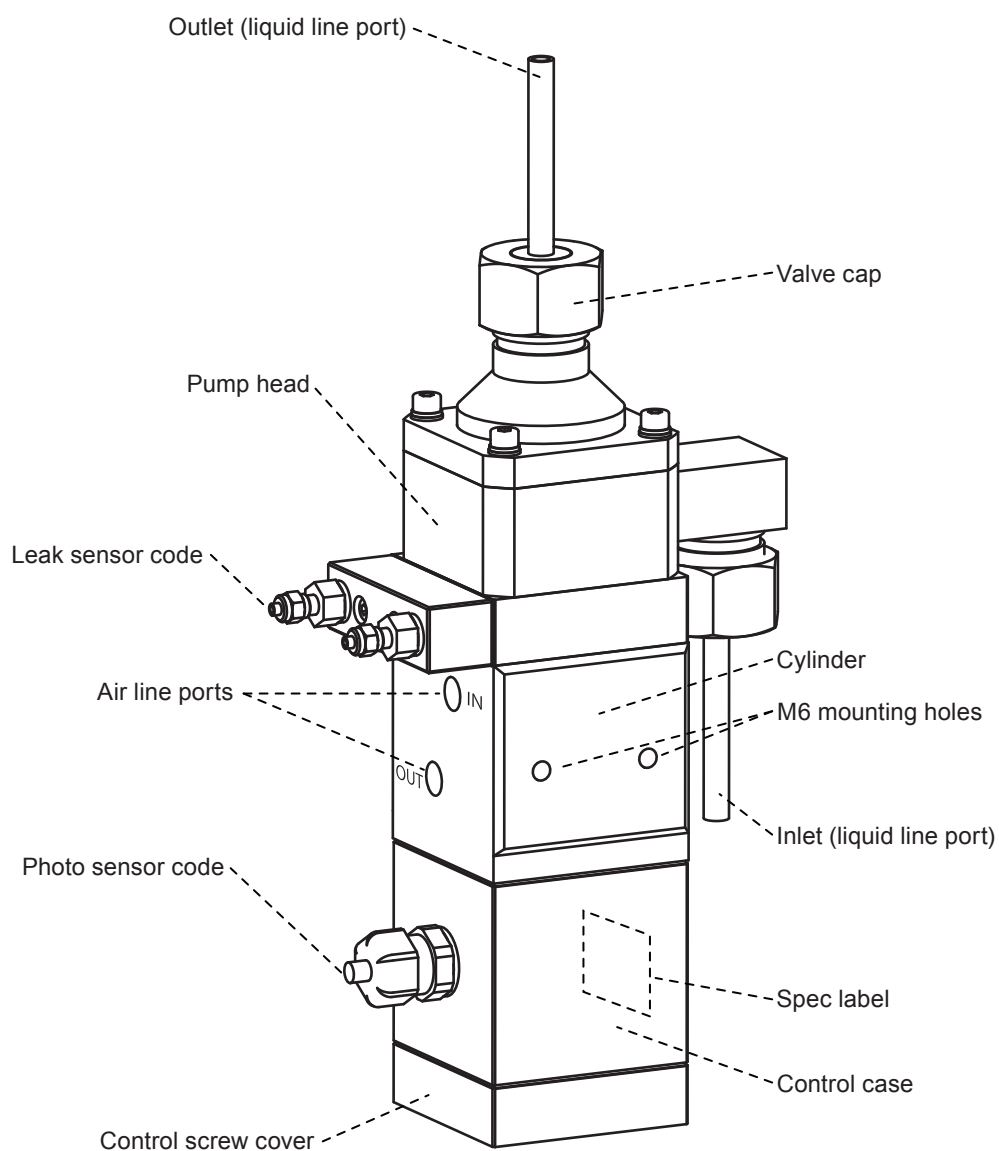

Installation

<i>1. Before installation</i>	<i>12</i>
<i>2. Installation/Piping/Wiring</i>	<i>14</i>

Installation

1. Before installation

■ Pneumatic system configuration

To operate this pump, pneumatic devices such as regulators, solenoid valves and speed controllers are required as well as Programmable Logic Controller (PLC). See below for a typical pneumatic system and select necessary components to your operating conditions. Note that any pneumatic devices are not included in the pump package. Purchase separately.

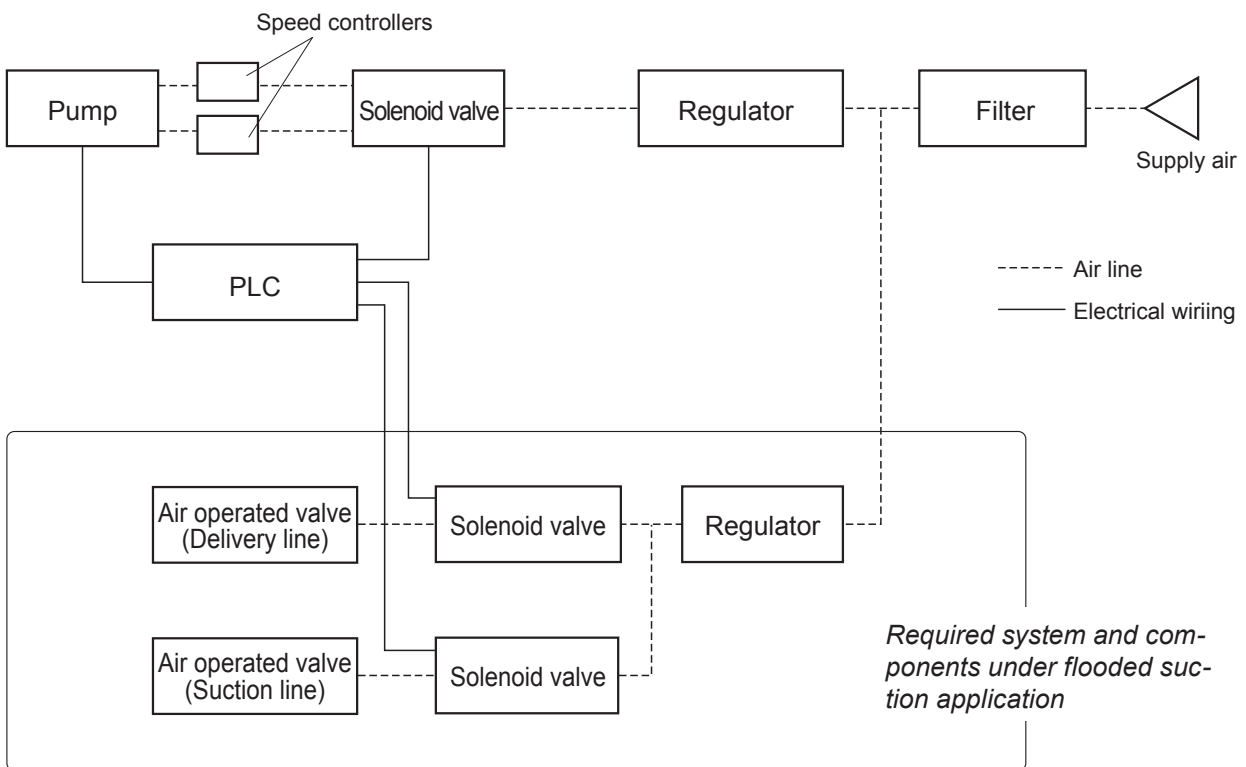

Installation

■ Points to be observed in operation

Read the following precautions thoroughly before operation in order to ensure the safe operation of the pump and system.

NO	Check items	Remarks
1	Pump stroke rate	Observe the allowable stroke rate range of 10-30spm.
2	Supply air pressure	Observe the allowable supply air pressure range of 0.15-0.3MPa.
3	Liquid temperature	Observe the allowable liquid temperature range of 20-60°C.
4	Prohibited solution	Liquid easily crystallizes, Slurry, Flammable liquid, Explosive liquid
5	Cautionary liquid	Stripper, Solvent, Hydrazine, Fuming sulfuric acid
6	The pump surface temperature	<p>Do not touch the pump or pipe with bare hands. Provide protection against burn injury as necessary. The surface temperature of the pump or pipe rises high along with liquid temperature in or right after operation.</p> <p><Reference data></p> <p>The surface temperature rises up to 48°C during the following operating condition.</p> <ul style="list-style-type: none"> •Clean water at 60°C •In a room temperature of 31°C •Stroke rate of 30spm
7	Noise emitted from the pump	<p>Substantial air exhaust noise is emitted from the pump during operation. Provide protection as necessary.</p> <p><Reference data></p> <p>Operating noise level of the pump: 31dB</p> <p>Operating noise level of the pump plus air exhaust noise level: 53dB*1</p> <p>Operating noise level of the pump plus air exhaust noise level: 45dB*2</p> <p>-The above data results from the following operating condition.</p> <ul style="list-style-type: none"> •Supply pressure of 0.3MPa •Stroke rate of 30spm •Clean water at a ambient temperature •Acoustic room of 25dB background noise level <p>*1 Solenoid valves with no silencer.</p> <p>*2 Solenoid valves with silencers.</p>

Installation

2. Installation/Piping/Wiring

Stop working upon perceiving any danger or abnormality.

WARNING

- Be sure to turn off the power before starting any maintenance/repair work. Make sure no one turns on the power while working on the pump, otherwise it may result in a serious accident. If your work field is noisy or dark, let other people know about the situation by displaying a notice such as "POWER OFF(Maintenance)" near the power switch.
- Electrical wiring works must be done by well-trained operator(s). We are not responsible for any injury or damage due to improper work.

CAUTION

- Stop working upon perceiving any danger or abnormality.

■ Installation

1. Pump installation position

Place the pump as close to the supply tank as possible.

2. Installation surface

Select a flat and solid foundation free from vibration.

3. Inlet/Outlet direction

Position the pump with its outlet up and inlet down so that the reciprocating motion of the piston rod and bellows is made in vertical direction. An anticipated performance will not met if it is made in a different direction. Be sure to secure the pump with anchor bolts, using M6 mounting holes. See page 10.

4. Access to the control screw

Keep the bottom of pump at least 15cm away from the nearest contacting surface. This room is required to remove the control screw cover to make stroke length adjustment. See page 26 for detail.

Installation

■ Pipework

WARNING

- **Countermeasure against efflux**

Take a protective measure against the accidental efflux caused by pump or liquid line breakage.

- **Countermeasure against the ingress of solid substances**

Do not allow solid substances to enter the pump, or it could lead to bellows breakage or valve clogging.

1. PFA tubes of 1/4" ($\phi 6.35 \times 4.35$) bore are provided to both the inlet and outlet of the pump.
2. Select joints suitable to the tube bore when connecting the pump with a plumbing system. The joints should be resistant to temperature change of heat cycle and plumbing vibration, and should keep sufficient air tight to prevent a leak.
3. Blow air into the tube or flush with tap water to remove foreign matters.
4. Joints should be tightened by hand only. Do not use excessive force or large wrenches. Support plumbing to prevent vibration or the effect of thermal stress.
5. Check tube connections (joints) free from a leak or air ingress.

Suction lift application

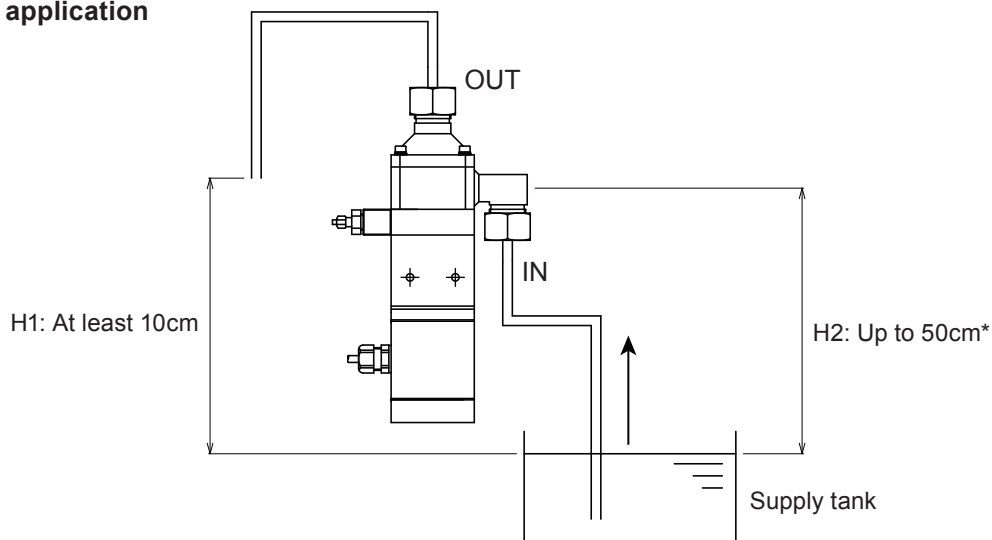

- a. The difference in height (H1) between the one end of discharge line (injection point) and the liquid level in the tank should be at least 10cm.
- b. The difference in height (H2) between the inlet of the pump head and the liquid level in the tank should be up to 50cm.

NOTE: The maximum priming lift of 50cm is obtained during operation with clean water at ambient temperature and is subject to liquid characteristics, temperature, and length of the whole suction line.

Installation

Flooded suction application

Siphonage occurs when one end of discharge line (injection point) is positioned below the supply tank.

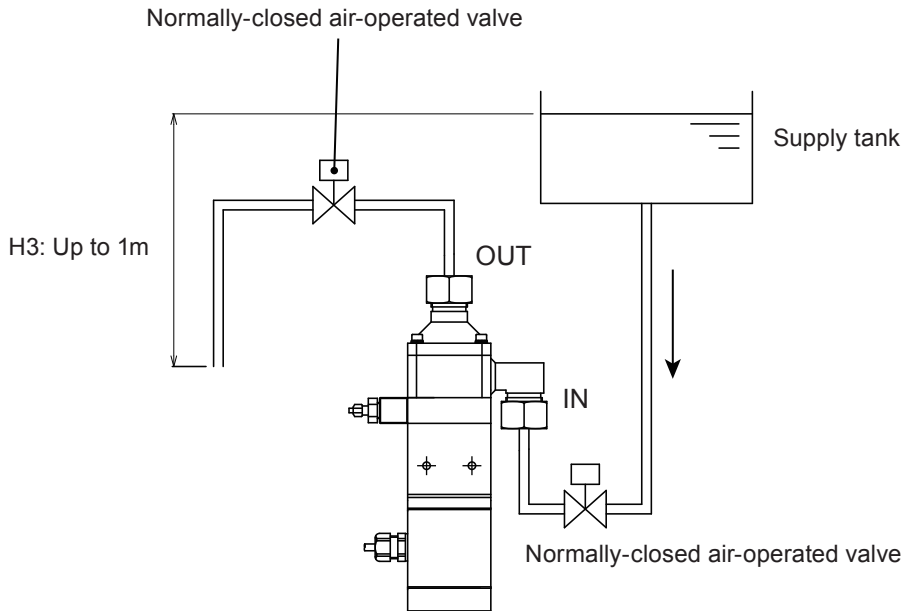

⚠ CAUTION

- Install an air operated valve on both discharge and suction lines as long as the pump is under flooded suction application. The difference in height (H3) between the one end of discharge line (injection point) and the liquid level in the tank should be up to 1m.
- To prevent siphonage from occurring during stoppage, supply air into the lower compartment divided by the piston in the air cylinder and keep the bellows in the pump chamber extended to the maximum.
- Always use normally-closed air-operated valves in flooded suction application. Although liquid is checked by not only air operated valves but also the bellows expanded to a maximum extent in the pump chamber to block a liquid flow, a normally-open type keeps a flow pass open at the time of system shutdown, spilling chemicals without control.

Installation

■ Air piping

CAUTION

- A qualified person should design, install and operate a pneumatic system. Read manufacture's instruction manual before work.
- Supply air should be free from moisture and dust. If supply air is contaminated with water, oil or dust, the pump may have trouble starting.
- Blow away dust and foreign matters from the inside of air lines, joints and solenoid valves before work.

1. Air piping connection

The bore of air line ports is Rc1/8". Observe the specified tightening torque of the joint to be mounted so that appropriate air tightness is obtained, however, do not exceed 1.6N•m or the port will suffer thread deformation or cracks.

2. Air consumption of the pump

The pump consumes air up to 2.5NL/min in operation at the stroke rate of 30spm, the supply air pressure of 0.3MPa and the discharge pressure of 0.05MPa. Select regulators, solenoid valves and speed controllers on the figure.

Installation

Pneumatic system (pump)

See the following diagram for a typical pneumatic system.

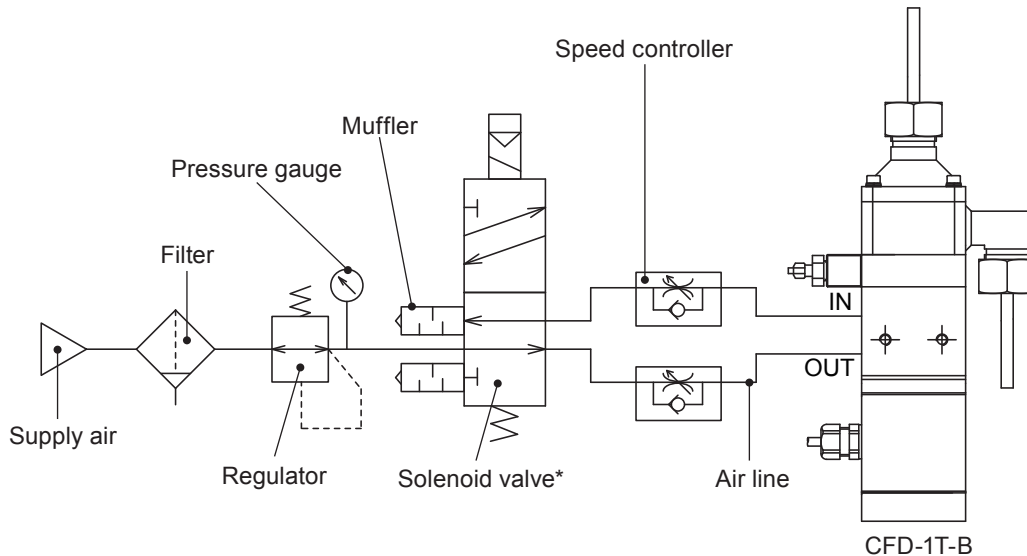

*The solenoid valve in this state is not electrified.

⚠ CAUTION

- Use a 2-position 5-port single solenoid valve to drive the pump. Be sure to connect "Normally Open" (N.O.) port of the valve with "OUT" air line port via an air line, and "Normally Closed" (N.C.) port with "IN". Always observe this connection, or operation ends up with system upset.

When the N.O. port is connected to "IN" air line port by mistake...

- a. The possibility of siphonage is normally controlled when the pump is stopped with the bellows expanded to a maximum extent in the pump chamber to block a liquid flow. This function will be unavailable due to incorrect connection.
- b. The control screw will be stuck and barely rotates for stroke length adjustment. Do not try to rotate the screw by excessive force in this situation, or screw thread may be damaged.

When using a 3-position 5-port double solenoid valve is used...

- a. Expected accuracy in a flow will not be met.
 - b. Photosensor signal output will not interlock with solenoid valve action.
- Mount speed controllers to configure a meter-out circuit. Do not make it a meter-in circuit. Or piston rod reciprocation will be upset and an accurate flow will not be obtained.

Installation

Pneumatic system with air-operated valves

See the following diagram for typical pneumatic system with air-operated valves.

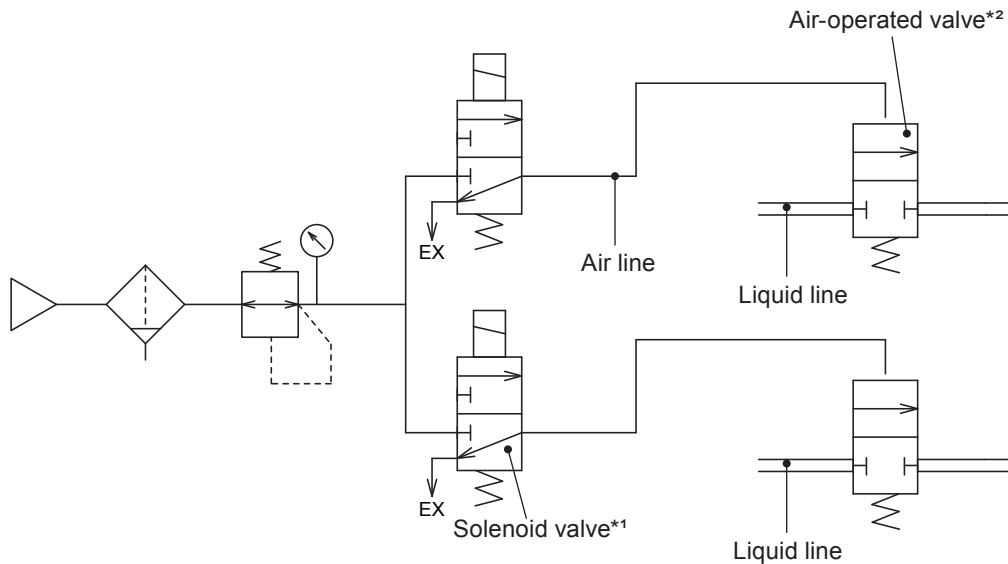

*1The solenoid valve in this state is not electrified.

*2The solenoid valve in this state is closed.

⚠ CAUTION

Although liquid is checked by not only air operated valves but also the bellows expanded to a maximum extent in the pump chamber to block a liquid flow, normally-open air-operated valves keep a flow pass open at the time of blackout or system shutdown spilling chemicals without control. In flooded suction application...

- Always use normally-closed air-operated valves.
- Use a 2-position 3-port single solenoid valve to control air-operated valves. Make sure that the valves are closed at system shutdown. Note that many commercial 3-port solenoid valves are universal porting type that a supply air port can be allocated to any port and the allocation of N.O. and N.C. ports changes accordingly. Be careful not to connect air lines incorrectly.

Installation

■ Electrical wiring

⚠ WARNING

Turn off power during electrical wiring.

Photo sensor output circuit

See the following diagram for connection between a photo sensor and your PLC.

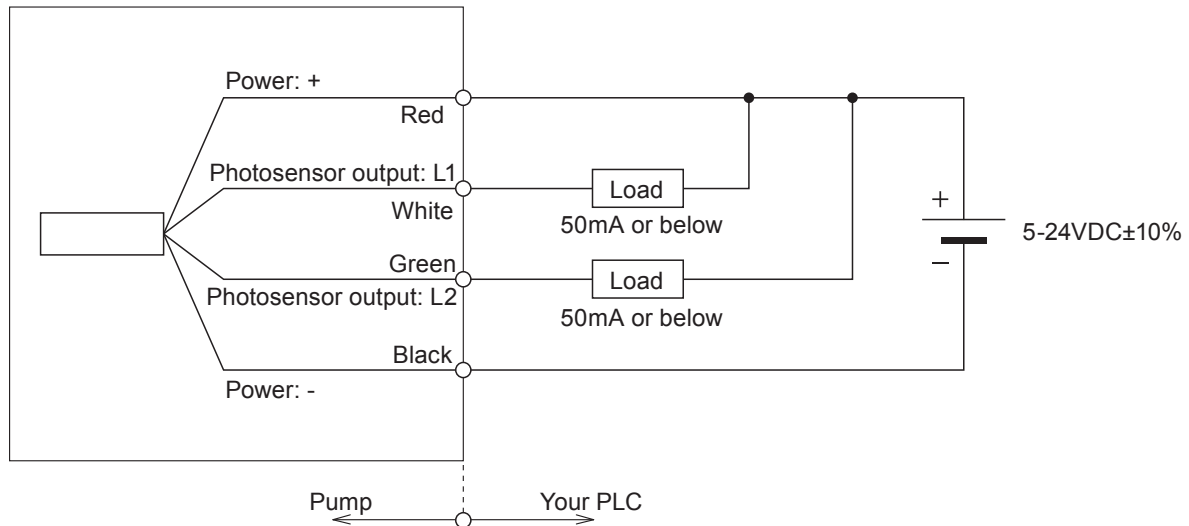

⚠ CAUTION

- Observe polarity. A protection circuit against reverse connection is not provided, so that the photo sensor may fail. Do not connect the power voltage directory to the photo sensor output lines of L1(white) and L2(green). A short-circuit protection is not provided, so that it also ends up with photo sensor failure.
- Observe the maximum load current of 50mA for the photo sensor output lines of L1(white) and L2(green). Otherwise photo sensors fail.
- Do not combine the photo sensor output lines with a high-voltage line such as power cable. Or it results in malfunction.
- Do not twist or pluck lead wires extended from the photo sensors. Disconnection may cause malfunction.
- Do not wet lead wires with chemical liquid. It could lead to malfunction of photo sensors when as chemical attacks the wires.
- Install a surge protection device as necessary to protect the circuit against surge voltage derived from a solenoid valve or motor.
- Note it takes 50msec after power on for photo sensors to work properly.
- Double check if electrical wiring is correctly completed before turning on power for operation.

⚠ WARNING

Photo sensors are not explosion proof. Do not use it with explosive or flammable liquid.

Installation

Leak sensor

Two electrodes will short-circuit when the bellows has broken and liquid starts to flow into the flange B, and will output an alarm signal. Note this function may not work for liquid with low conductivity.

WARNING

Use of the leak sensor is prohibited when a flammable liquid such as solvent is pumped. A spark in a solvent may cause a fire.

Photo sensors

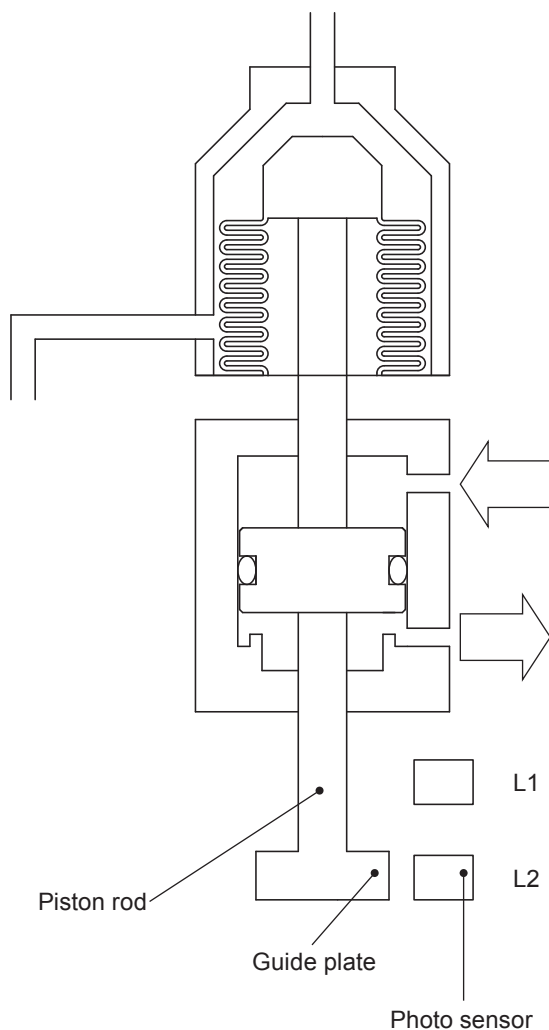

1. When air is supplied to the upper compartment divided by the piston in the air cylinder, the piston rod moves down to contract the bellows so as to introduce liquid into the pump chamber (Suction process).
2. The left diagram shows that the piston rod has backed down to the maximum extent possible and the guide plate at the bottom of the piston rod has come closest to the L2 photo sensor. At this time the L2 sends out a signal in order for the PLC to change over solenoid valve into the other position and to start discharge process supplying air into the lower compartment of the cylinder.
3. When the piston rod reaches to the maximum extent possible and the guide plate at the bottom of the piston rod has come closest to the L1 photo sensor, the L1 sends out a signal in order for the PLC to change over solenoid valve into the other position and to resume suction process again.
4. These process are repeated during operation.
5. At the last shot to stop the pump, keep the piston rod extended to the maximum with the lower compartment of the cylinder pressurized. Do not change over the solenoid valve position into another.
Resume operation, starting from the step 1 above.

Installation

Timing chart

Set relevant devices for sequence control. Use the timing chart below for your reference.

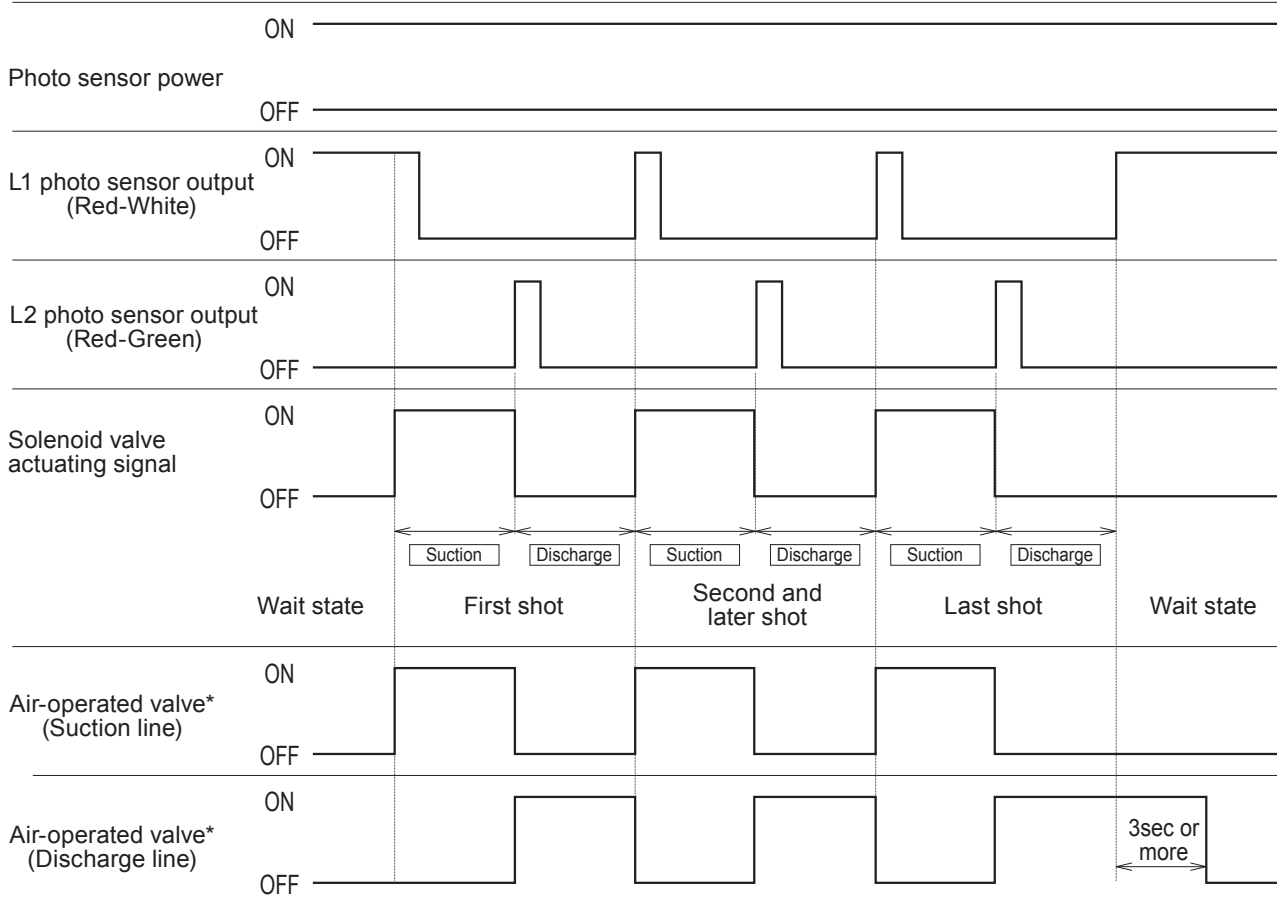

*Air-operated valves are required for flooded suction application

⚠ CAUTION

State	Description
Wait state	L1 photo sensor output should be ON. If not, air line or electrical wiring or both are incorrectly arranged.
Suction process	After L1 photo sensor output turns OFF, solenoid valve actuating signal should be kept ON until L2 photo sensor output turns ON.
Discharge process	After L2 photo sensor output turns OFF, solenoid valve actuating signal should be kept OFF until L1 photo sensor output turns ON.
Shutdown	In the last shot just before stopping operation, solenoid valve actuating signal should be kept OFF even after L1 photo sensor output turns ON. <i>When using air-operated valves...</i> Just after the last shot, the air-operated valve on the discharge line should not close just as L1 photo sensor turns ON. The valve should wait at least <u>3 seconds</u> before closing the line, or the bellows may deform due to the rise of impact or residual pressure.

Operation

<i>1. Before operation</i>	<i>24</i>
<i>2. Operation</i>	<i>24</i>
<i>3. Adjustment of liquid volume per shot</i>	<i>25</i>
<i>4. Check items</i>	<i>27</i>

Operation

1. Before operation

Carry out the following preparatory steps when first starting the pump after installation or resuming operation after a long period of storage.

1. Check that electric wiring is correct (Wiring for photo sensors, electrodes and solenoid valve).

CAUTION

Improper wiring leads to malfunction or failure.

2. Check that the air piping are correct. Check for a loose joint.
3. Check that the pump is anchored in place.
4. Check that the liquid piping are correct. Check for a loose joint.
5. Check that the tank is filled with liquid.

CAUTION

Before operation in your system, flush away foreign matters with pure water (or chemical liquid).

2. Operation

■ Starting the pump

1. *Open all manually-operated valves if installed.*
2. *Supply air to the pump. Observe the supply air pressure range of 0.15-0.3MPa. Also, supply power to photo sensors.*
3. *Run the pump, switching solenoid valves by a PLC to make operation in programmed sequence control.*
4. *Stop operation after the required number of shots has been completed.*

CAUTION

Observe the following points when stopping operation.

- At the last shot to stop the pump, keep the piston rod extended to the maximum by pressurizing the lower compartment in the cylinder through the "OUT" air line port.
- The air-operated valve on the discharge line should not close the line just as the pump stops.

Operation

3. Adjustment of liquid volume per shot

Volume per shot can be changed by the use of speed controllers or stroke length adjustment, or both.

Factory default setting	1mL/shot at 30spm
Adjustment range	0.4-2.7mL/shot
Stroke speed range	10-30spm

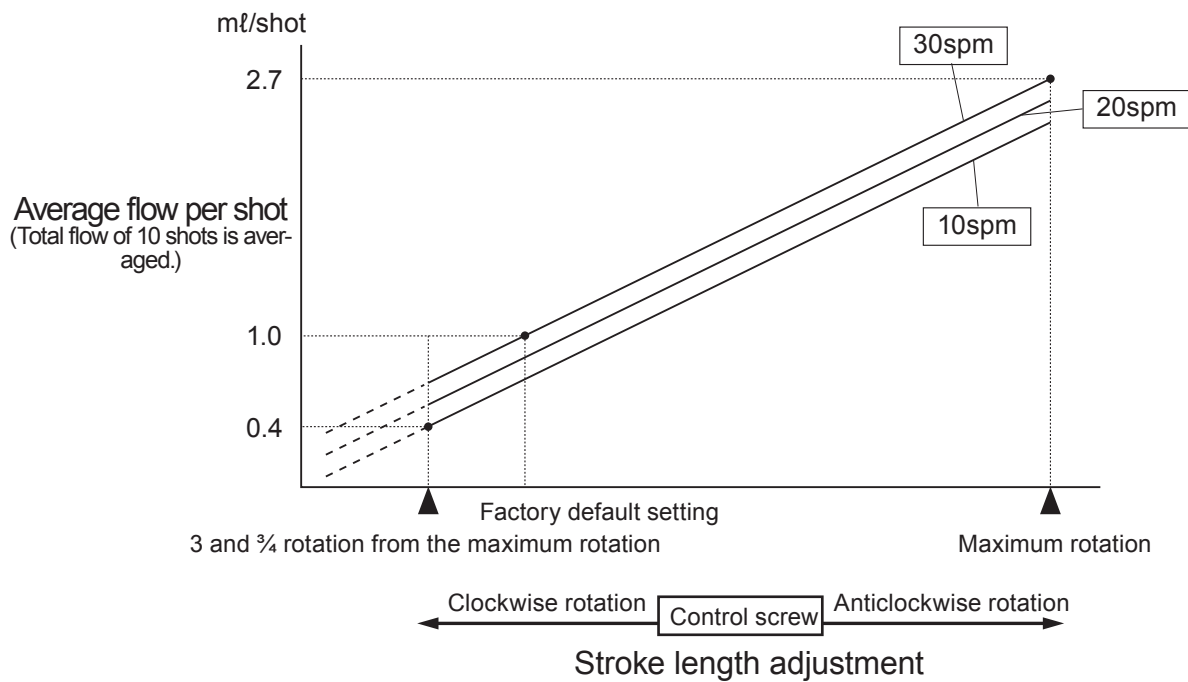

NOTE: Factory default stroke length is set to meet 1mL/shot at 30spm. Note that the volume per shot may reduce as stroke rate decreases with the same stroke length.

■ Stroke rate control by speed controllers

Volume per shot can be adjusted by changing not only stroke length but also stroke rate in between 10-30spm via speed controllers. Always make both the discharge and suction rates are almost the same.

Operation

■ Stroke length adjustment

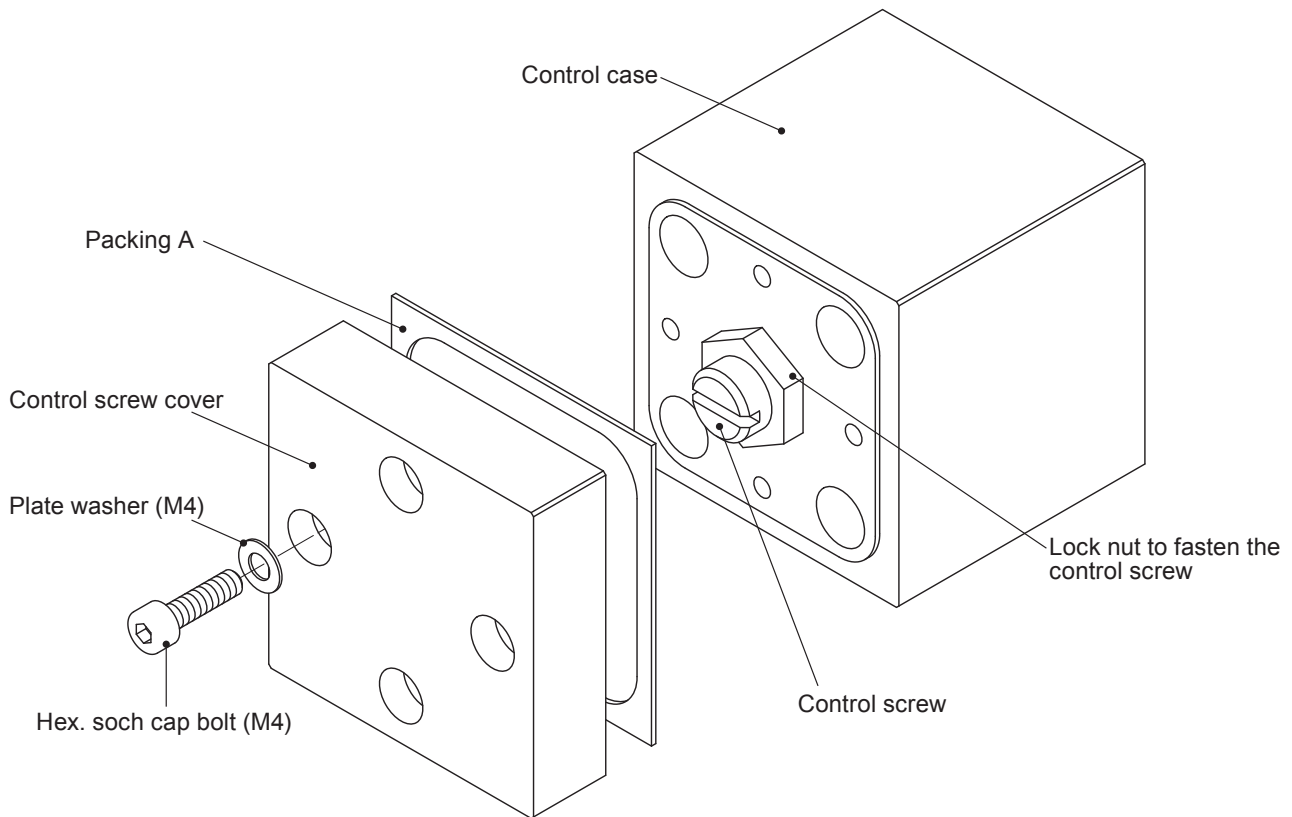

1. Stop the pump with "OUT" air line port pressurized.
2. Remove the control screw cover and the packing A.
3. Loosen the lock nut.
4. Use a slotted screwdriver to...
 - Rotate the control screw anticlockwise to extend the stroke length and to increase volume per shot. The stroke length will be fully-extended at the maximum rotational extent.
 - Rotate the control screw clockwise to contract the stroke length and to decrease volume per shot. Do not make three and three-quarter rotation or more from the maximum stroke length position above, or the pump will not work properly because stroke length is too short.
5. Make stroke length adjustment while measuring volume per shot for assuring a correct flow.
6. Hold the control screw by a slotted screwdriver to prevent it from moving while fastening the lock nut.
7. When installing the control screw cover, check the packing A is in place and will not be pinched or twisted.

Operation

4. Check items

Pay attention to the following points during operation.

Upon detecting any abnormality, stop the pump and see "Troubleshooting" on page 29.

#	Check items	Remarks
1	Pump stroke rate	Observe the range of 10-30spm.
2	Supply air pressure	Observe the range of 0.15-0.3MPa.
3	Supply air rate	
4	Joints on air/liquid lines	
5	Cleanness of supply air	

Maintenance

<i>1. Troubleshooting</i>	<i>29</i>
<i>2. Maintenance & Inspection.....</i>	<i>30</i>
<i>3. Wear parts</i>	<i>30</i>

Maintenance

1. Troubleshooting

Trouble	Causes	Measures
The pump does not run.	<ul style="list-style-type: none"> ● Bellows rupture (Alarm output) 	<ul style="list-style-type: none"> ○ Replace the pump with new one.
	<ul style="list-style-type: none"> ● Alarm output due to erroneous detection by a leak sensor. 	<ul style="list-style-type: none"> ○ Check the electrode cover and electrical wiring to see if they are not wet with chemical liquid. Replace as necessary.
	<ul style="list-style-type: none"> ● Photo sensor malfunction <ul style="list-style-type: none"> • Photo sensor failure • Power failure 	<ul style="list-style-type: none"> ○ Check and replace as necessary. ○ Check and replace as necessary.
	<ul style="list-style-type: none"> ● Supply air pressure or air volume is too low. <ul style="list-style-type: none"> • Compressor failure • Set pressure of the relief valve is too low. • Air filter clogging • Air leak from pneumatic devices or joints • Air flow is reduced by speed controllers and is too low. 	<ul style="list-style-type: none"> ○ Inspect and repair as necessary. ○ Set the pressure to a proper level. ○ Clean and replace as necessary. ○ Inspect and repair as necessary. ○ Adjust speed controllers to keep a necessary air flow.
	<ul style="list-style-type: none"> ● A solenoid valve does not function. 	<ul style="list-style-type: none"> ○ Inspect, repair or replace as necessary.
	<ul style="list-style-type: none"> ● Improper wiring or disconnection 	<ul style="list-style-type: none"> ○ Inspect, repair or replace as necessary.
	<ul style="list-style-type: none"> ● Incorrectly laid air line 	<ul style="list-style-type: none"> ○ Check and correct as necessary.
	<ul style="list-style-type: none"> ● Sequence control is upset. 	<ul style="list-style-type: none"> ○ Check and correct sequence control.
The pump runs with no discharge.	<ul style="list-style-type: none"> ● Bellows rupture 	<ul style="list-style-type: none"> ○ Replace the pump with new one.
	<ul style="list-style-type: none"> ● Air operated valve failure <ul style="list-style-type: none"> • Valve clogging • Incorrectly laid air line • Supply air pressure is too low. 	<ul style="list-style-type: none"> ○ Inspect, repair or replace as necessary. ○ Inspect or correct air line. ○ Set the pressure to a proper level.
	<ul style="list-style-type: none"> ● Air ingress from a suction line 	<ul style="list-style-type: none"> ○ Check a chemical tank, liquid line and joint. Repair as necessary.
	<ul style="list-style-type: none"> ● NPSHa is too low. 	<ul style="list-style-type: none"> ○ Check suction line and correct as necessary.
	<ul style="list-style-type: none"> ● Pump head valves do not work properly. <ul style="list-style-type: none"> • Clogging • Improper mounting position 	<ul style="list-style-type: none"> ○ Inspect, repair or replace as necessary. ○ Observe the correct mounting position (vertical mounting).
Discharge volume is reduced.	<ul style="list-style-type: none"> ● Supply air pressure or air volume is too low. 	<ul style="list-style-type: none"> ○ See the measure to the same cause described above.
	<ul style="list-style-type: none"> ● Air-operated valve failure 	<ul style="list-style-type: none"> ○ See the measure to the same cause described above.
	<ul style="list-style-type: none"> ● NPSHa is too low. 	
	<ul style="list-style-type: none"> ● Pump head valves do not work properly. 	<ul style="list-style-type: none"> ○ Check a discharge line and correct as necessary.
	<ul style="list-style-type: none"> ● Discharge pressure rise 	
	<ul style="list-style-type: none"> ● Worn O ring in the drive unit 	<ul style="list-style-type: none"> ○ Check and replace as necessary.
	<ul style="list-style-type: none"> ● Supply air flow and pressure is unstable. 	<ul style="list-style-type: none"> ○ Check and replace as necessary.

Maintenance

2. Maintenance & Inspection

⚠ WARNING

- **Wear protectors**

Always wear protective clothing (protective goggles, cap, mask, etc.) during maintenance and inspection work. Rinse the pump with tap or pure water to remove chemicals.

- **Turn off power and air supply before work**

Be sure to turn off power to stop the pump and air supply before work. Make sure no one turns on the power by mistake while working on the pump, otherwise it may result in a serious accident. If your work field is noisy or dark, let other people know about the situation by displaying a notice such as "POWER OFF (Maintenance)" near the power switch.

- **Release pressure out of liquid line**

Residual pressure in a liquid line may splash liquid and cause an unexpected accident. Release the residual pressure before work.

- **Assure safety before turning on power**

Always check the pump and pneumatic devices before resuming operation in order to prevent system upset or malfunction.

■ Daily inspection

Check the following items to assure safe operation

1. Pumping
2. Air leak from pneumatic devices or air line
3. Supply air cleanness
4. Supply air pressure
5. Supply air rate
6. Evidence of a leak

3. Wear parts

The wear parts shown below should be replaced when they reach the estimated life end or when performance has deteriorated remarkably, whichever comes fast. Contact us for replacement.

Part No.*1	Part names	Q'ty*2	Remarks	Estimated life*3
2	Bellows	1		One year (in continuous operation)
17	O ring	1	P-8	
18	O ring	1	P-14	
19	O ring	1	P-22A	
53	Valve gasket	6		
55	Valve ball	2	3/16"	
56	Valve seat	2		

*1 See "5. Part names & Structure" on page 9.

*2 Q'ty shows the number of parts per pump.

*3 The estimated life span varies with operating conditions and is not warranted.

IWAKI PUMPS



()Country codes
IWAKI CO.,LTD. 6-6 Kanda-Sudacho 2-chome Chiyoda-ku Tokyo 101-8558 Japan
 TEL:(81)3 3254 2935 FAX:3 3252 8892(<http://www.iwakupumps.jp>)

Australia	IWAKI Pumps Australia Pty. Ltd.	TEL : (61)2 9899 2411	FAX : 2 9899 2421	Italy	IWAKI Italia S.R.L.	TEL : (39)02 990 3931	FAX : 02 990 42888
Austria	IWAKI (Austria) GmbH	TEL : (43)2236 33469	FAX : 2236 33469	Korea	IWAKI Korea Co.,Ltd.	TEL : (82)2 2630 4800	FAX : 2 2630 4801
Belgium	IWAKI Belgium n.v.	TEL : (32)1367 0200	FAX : 1367 2030	Malaysia	IWAKIm Sdn. Bhd.	TEL : (60)3 7803 8807	FAX : 3 7803 4800
China	IWAKI Pumps (Shanghai) Co., Ltd.	TEL : (86)21 6272 7502	FAX : 21 6272 6929	Norway	IWAKI Norge AS	TEL : (47)66 81 1660	FAX : 66 81 1661
China	IWAKI Pumps (Guandong) Co., Ltd.	TEL : (86)750 3866228	FAX : 750 3866278	Singapore	IWAKI Singapore Pte. Ltd.	TEL : (65)6316 2028	FAX : 6316 3221
China	GFTZIWAKI Engineering & Trading (Guangzhou)	TEL : (86)20 8435 0603	FAX : 20 8435 9181	Spain	IWAKI Iberica Pumps, S.A.	TEL : (34)943 630030	FAX : 943 628799
China	GFTZIWAKI Engineering & Trading (Beijing)	TEL : (86)10 6442 7713	FAX : 10 6442 7712	Sweden	IWAKI Sverige AB	TEL : (46)8 511 72900	FAX : 8 511 72922
Denmark	IWAKI Nordic A/S	TEL : (45)48 24 2345	FAX : 48 24 2346	Switzerland	IWAKI (Schweiz) AG	TEL : (41)26 674 9300	FAX : 26 674 9302
Finland	IWAKI Suomi Oy	TEL : (358)9 2745810	FAX : 9 2742715	Taiwan	IWAKI Pumps Taiwan Co., Ltd.	TEL : (886)2 8227 6900	FAX : 2 8227 6818
France	IWAKI France S.A.	TEL : (33)1 69 63 3370	FAX : 1 64 49 92 73	Taiwan	IWAKI Pumps Taiwan (Hsin-chu) Co., Ltd.	TEL : (886)3 573 5797	FAX : (886)3 573 5798
Germany	IWAKI EUROPE GmbH	TEL : (49)2154 92540	FAX : 2154 9254 48	Thailand	IWAKI (Thailand) Co.,Ltd.	TEL : (66)2 322 2471	FAX : 2 322 2477
Holland	IWAKI Holland B.V.	TEL : (31)547 293 160	FAX : 547 292 332	U.K.	IWAKI Pumps (UK) LTD.	TEL : (44)1743 231363	FAX : 1743 366507
Hong Kong	IWAKI Pumps Co., Ltd.	TEL : (852)2 607 1168	FAX : 2 607 1000	U.S.A.	IWAKI AMERICA Inc.	TEL : (1)508 429 1440	FAX : 508 429 1386
Indonesia	IWAKI Singapore (Indonesia Branch)	TEL : (62)21 690 6606	FAX : 21 690 6612	Vietnam	IWAKI pumps Vietnam Co.,Ltd.	TEL : (84)613 933456	FAX : 613 933399