



***IWAKI AMERICA
LK SERIES
METERING PUMP
INSTRUCTION MANUAL***



Notice

© 2013 Iwaki America Inc
Five Boynton Road, Holliston, MA 01746 USA
tel (508) 429-1440 fax (508) 429-1386
All Rights Reserved
Printed in USA

Proprietary Material

The information and descriptions contained herein are the property of Iwaki America Inc. Such information and descriptions may not be copied or reproduced by any means, or disseminated or distributed without the express prior written permission of Iwaki America Inc.

This document is for information purposes only and is subject to change without notice.

Statement of Limited Warranty

Iwaki America warrants equipment of its manufacture and bearing its identification to be free from defects in workmanship and material for a period of one year from date of delivery from the factory or authorized distributor under normal use and service and otherwise when such equipment is used in accordance with instructions furnished by Iwaki America and for the purposes disclosed in writing at the time purchased, if any. Iwaki America's liability under this warranty shall be limited to replacement or repair, F.O.B. Holliston, MA U.S.A. of any defective equipment or part which, having been returned to Iwaki America, transportation charges prepaid, has been inspected and determined by Iwaki America to be defective.

THIS WARRANTY IS IN LIEU OF ANY OTHER WARRANTY, EITHER EXPRESS OR IMPLIED, AS TO DESCRIPTION, QUALITY, MERCHANTABILITY, FITNESS FOR ANY PARTICULAR PURPOSE OR USE, OR ANY OTHER MATTER.

*P/N 180312.L
May 2013*

TABLE OF CONTENTS

Thank you for choosing an Iwaki America LK Series Metering Pump. This instruction manual deals with the correct installation, operation, maintenance and troubleshooting procedures for the LK metering pumps. Please read through it carefully to ensure the optimum performance, safety and service of your pump.

IMPORTANT INSTRUCTIONS	1
1 Operating Principle	3
2 Model Identification Guide	4
3 Specifications and Outer Dimensions	4
4 Names of Parts	7
5 Description on Main Unit and Label	16
6 Handling Instructions	17
7 Installation	18
8 Piping	19
9 Wiring	21
10 Operating Instructions	21
11 Troubleshooting	26
12 Maintenance and Inspection	27
13 Spare Parts	29
14 Disassembly and Assembly	29

IMPORTANT INSTRUCTIONS

Important notes and statements about the safe operation and prevention of physical injury and/or property damage are included throughout this instruction manual.

Always Observe These Safety Instructions!

Safety Instructions to Prevent Personal Injury

In this manual, the following symbols and signs are used to clearly indicate safety instructions:



Warning

Non-observance or misapplication of the contents of the "Warning" section could lead to a serious accident, including death or injury.



Caution

Non-observance or misapplication of the contents of the "Caution" section could lead to serious physical injury to the user or serious damage to the product.



Caution

(Always read and observe the following instructions to prevent personal injury.)

- ***Wear gloves when working with rope or chain.*** Working with bare hands may result in serious injury, since fingers are likely to be caught between the pump and the rope or chain when the rope or chain is under tension.
- ***The pump is not designed to be used under water.*** Install the pump in a clean, dry environment where the pump cannot become submerged. It is recommended that the pump be shielded from direct exposure to the elements.
- ***Install a safety valve on the discharge line.*** Installation of a pressure relief valve is highly recommended. Check local codes and regulations.
- ***Do not close off the discharge or suction lines while the pump is operating.*** The pump or piping may become damaged.



Warning

(Always read and observe the following instructions to prevent personal injury.)

- **Damaged or deteriorated tools are very dangerous.** Use only qualified and suitable tools.
- **Use protective gear.** When disassembling, assembling, and conducting maintenance or when handling a dangerous type of liquid or a liquid of unknown property, be sure to wear safety gloves, a helmet, and protective shoes. In addition, when handling wet-end parts, always wear protective goggles, masks, etc.
- **Prevent death or injury from a falling pump.** Make sure the rope or chain used for lifting the pump is not accidentally cut or disconnected during installation. Make sure the rope or the chain used to lift the pump has sufficient strength for the pump load. Do not stand underneath a lifted or suspended pump.
- **Always turn off the power supply prior to servicing the pump.** Make special provisions so that the power supply cannot be turned on while someone is working on the pump. In a noisy or poor visibility environment, display a sign near the power supply switch to notify others that someone is "WORKING" on the pump. Power mistakenly applied during maintenance may lead to personal injury.
- **Check and make sure that there is no one near the pump when switching on the power supply.** The pump is not equipped with an ON/OFF switch. Connecting the power cable or power plug supplies the power to the pump and starts the operation.
- **Run the pump at the specified power supply voltage on the nameplate only.** Fire or electric shock may result if the supply voltage is incorrect.
- **If pump operation is stopped due to a power failure or closure of discharge line,** turn off the power switch at once. After normal conditions are established, reapply power.
- **Do not use the pump for anything that it is not designed to do.** User's failure to observe this instruction exempts Iwaki America from any responsibility for personal injury or damage to the equipment or facility caused by the pump's misuse.
- **When handling liquid with toxic or strong vapors,** ventilate the working area well. In addition, the operator must wear protective gear (such as a safety mask, safety goggles, and protective gloves).
- **Do not allow toxic substances such as lubricants, solvents, or similar substances to flow into the local sewage system or river systems.** Do not drain hazardous liquids such as chemical solutions discharged out of the pump directly onto the ground. Instead, drain such liquids into an appropriate container. Observe the laws and regulations related to the application, handling, and processing of hazardous substances.

1 Operating Principle

The rotation of the motor is reduced by means of the worm and wheel. The rotary motion is converted to a reciprocating motion by the spring-back mechanism (including the worm wheel shaft, slider, spring, etc.). The reciprocating motion is transmitted to the diaphragm directly connected with the shaft, changing the volume inside the pump chamber. The variation in volume inside the pump chamber and the functioning of the valves in the pump head produce the pump operation. To adjust stroke length, the adjusting dial fixed on the control shaft is rotated to change the return of the slider.

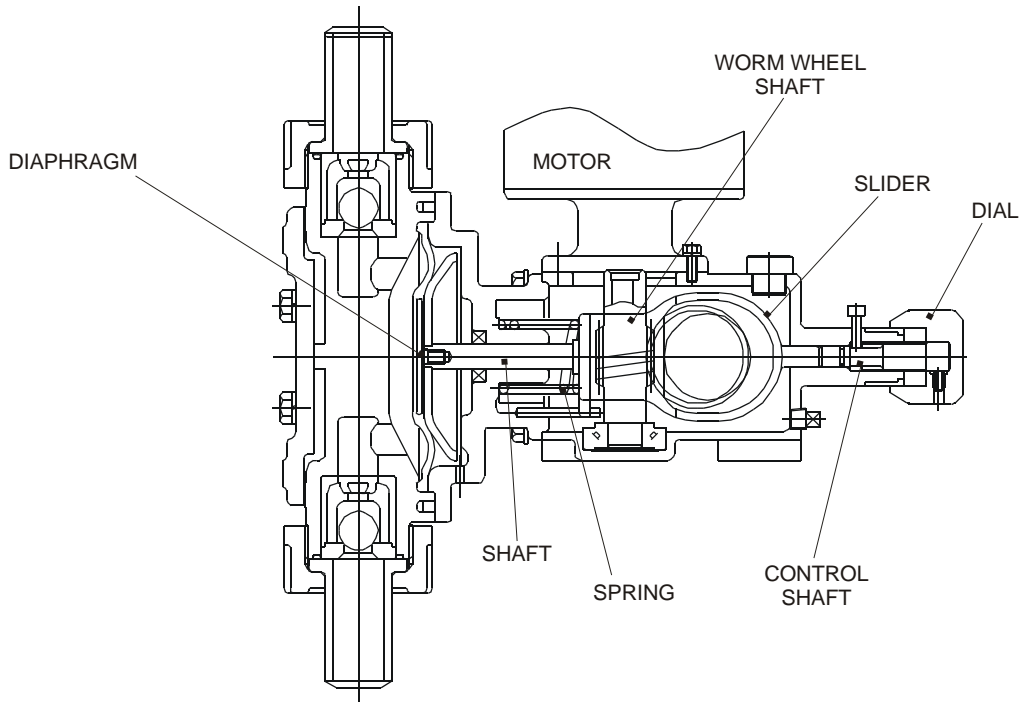

2 Model Identification Guide

LK	N	32	A	-	VC
1	2	3	4		5

- 1** LK Series motor-driven metering pump
- 2** N – NEMA 42C motor mounting flange
- 3** Capacity/Pressure Rating. Refer to specifications and outer dimensions below.
- 4** Motor Code:
 - A = 115/230V, 60Hz, 1 ph, 1/3 HP, 1725 RPM, TEFC Frame 42C
 - B = 230/460V, 60Hz, 3 ph, 1/3 HP, 1725 RPM, TEFC Frame 42C
 - C = 190/380V//230/460V, 50/60Hz, 3 ph, 1/3 HP, 1450/1725 RPM, TEFC, Frame 42C
 - D = 90VDC, 1 ph, 1/3 HP, 1750 RPM, TENV, Frame 42C Variable Speed Motor, 115V Control
 - E = 180VDC, 1 ph, 1/3 HP, 1750 RPM, TENV, Frame 42C Variable Speed Motor, 230V Control
 - F = 230/460V, 60Hz, 3 ph, 1/3 HP, 1725 RPM, Explosion Proof Motor: Class 1, Div 1, Group C & D
 - G = 230/460, 60 Hz, 3 ph, 1725 RPM, Inverter Duty Motor, TENV, 42C
- 5** Liquid End Code. Refer to the table below.

Material symbol		VC	VH	VS	TC	S6	
Part	Pump head	PVC	PVC	PVC	PVDF	316 SS	
	Valve ball	CE	HC	HC/304 SS	CE	HC	
	Valve seat	Type 32	FKM	EPDM	304 SS	FKM	316 SS
		Type 45 to 57	PVC	PVC	304 SS	PVDF	316 SS
	O ring	FKM	EPDM	EPDM	FKM	-	
	Valve gasket	PTFE					
	Diaphragm	PTFE + EPDM					

CE: Alumina ceramic HC: Hastelloy C267

3 Specifications and Outer Dimensions

Model	Capacity		Maximum Pressure PSI (MPa)		Stroke speed (spm)		Connection NPT		Viscosity cps
	50Hz (l/h)	60Hz (GPH)	PVC/PVDF	SS	50Hz	60Hz	PVC/PVDF	SS	
LKN32	30	9.5	150 (1)	225 (1.5)	96	116	½"	½"	VC: 300 TC: 300 VH: 500 VS: 1000 S6: 1000
LKN45	50	15.9	150 (1)	225 (1.5)	48	58	½"	½"	
LKN47	100	31.8	120 (0.8)	120 (0.8)	96	116	½" *	½"	
LKN55	168	53.4	75 (0.5)	75 (0.5)	48	58	1"	1"	
LKN57	360	114.3	45 (0.3)	45 (0.3)	96	116	1"	1"	

* LKN47-VS has 1" NPT connections

Outer dimensions

■ LKN32, 45, 47, 55, 57, VC, VH, VS

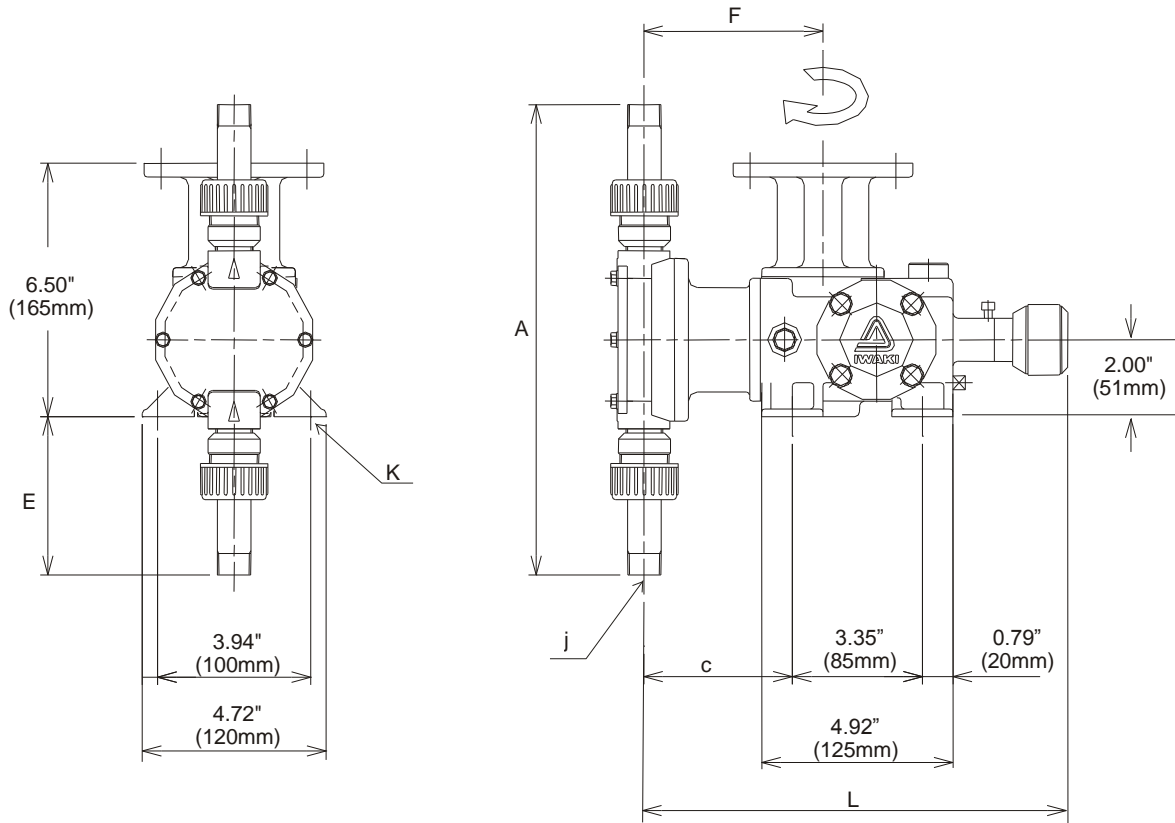

Dimensions in inches (mm)

Model	L	A	C	E	F	J	K
LKN32, VC, VH, VS	10.88 (276)	12.125 (308)	3.88 (99)	4.063 (103)	4.688 (119)	½" NPT	4 x ø0.35" (ø9)
LKN45, 47, VC, VH, VS	10.94 (278)	12.00 (305)	3.94 (100)	4.00 (102)	4.75 (121)		
LKN47VS	10.94 (278)	10.125 (257)	3.94 (100)	3.06 (78)	4.75 (121)	1" NPT	
LKN55, 57, VC, VH, VS	12.375 (314)	12.25 (311)	4.50 (114)	4.125 (105)	5.313 (135)		

Outer Dimensions

■ LKN32, 45, 47, 55, 57, S6

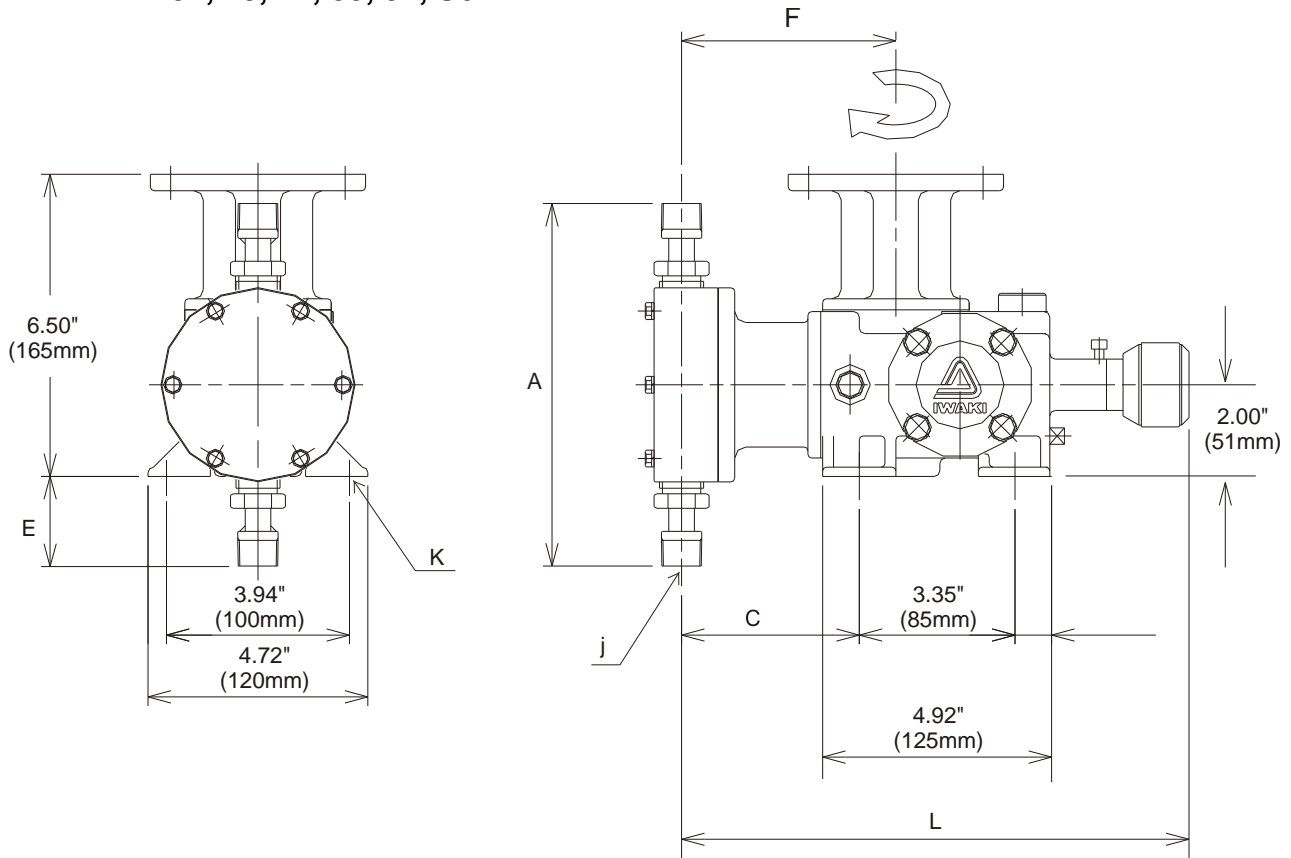

Dimensions in inches (mm)

Model	L	A	C	E	F	J	K
LKN32, S6	10.88 (276)	7.95 (202)	3.88 (99)	1.88 (48)	4.688 (119)	½" NPT	4 x ø0.35" (ø9)
LKN45, 47, S6	11.00 (279)	12.00 (305)	4.00 (102)	4.00 (102)	4.81 (122)		
LKN55, 57, S6	12.125 (308)	15.25 (387)	4.25 (108)	5.625 (143)	5.188 (132)	1" NPT	

Outer Dimensions

■ LKN32, 45, 47, 55, 57, TC

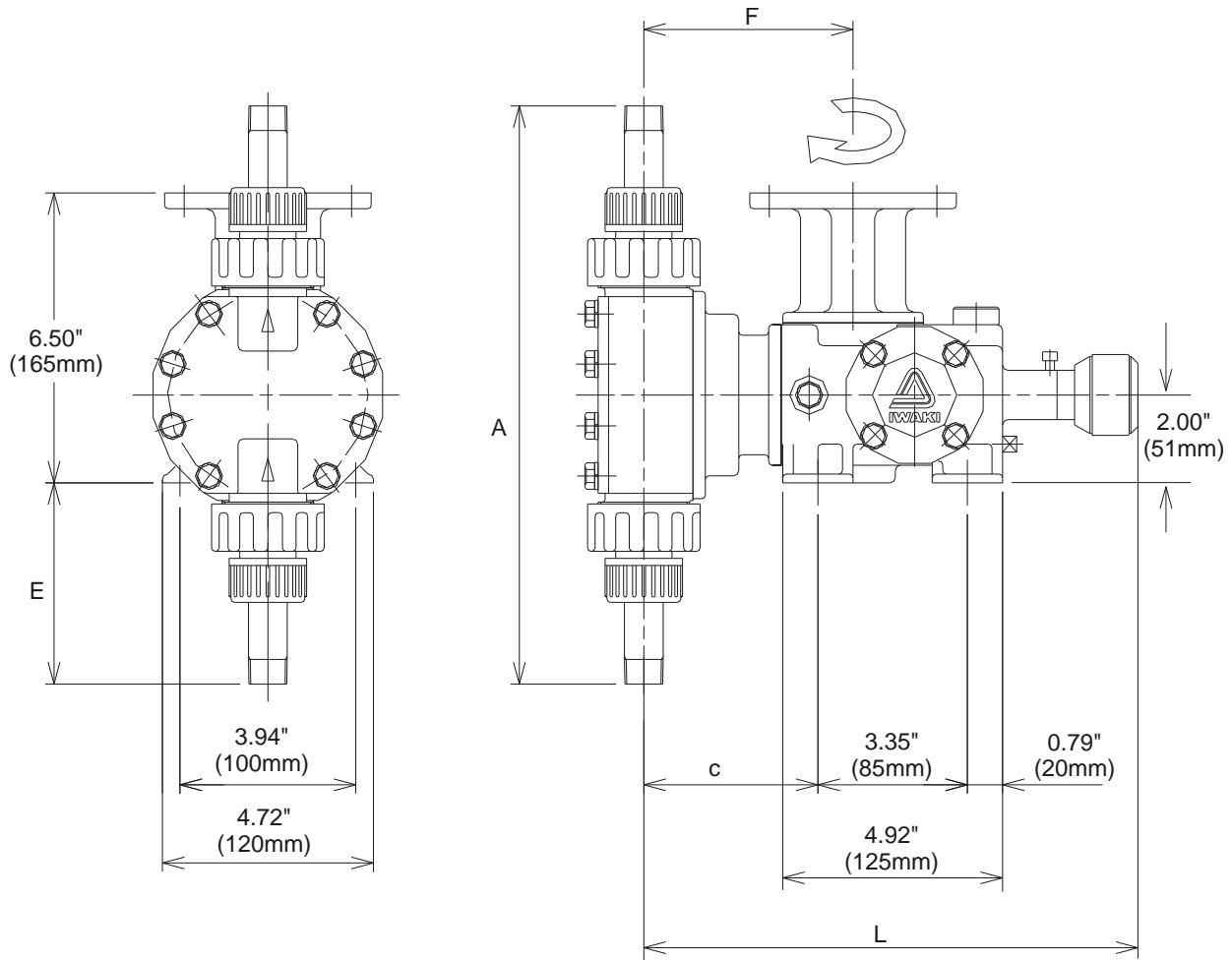

Dimensions in inches (mm)

Model	L	A	C	E	F	J	K
LKN32, TC	10.88 (276)	12.125 (308)	3.88 (99)	4.06 (103)	4.688 (119)	½" NPT	4 x ø0.35" (ø9)
LKN45, 47, TC	10.44 (265)	13.50 (343)	3.44 (87)	4.75 (121)	4.75 (121)		
LKN55, 57, TC	12.375 (314)	12.25 (311)	4.50 (114)	4.188 (106)	4.125 (105)	1" NPT	

4 Exploded View and Parts List

■ LKN32 VC, VH, VS

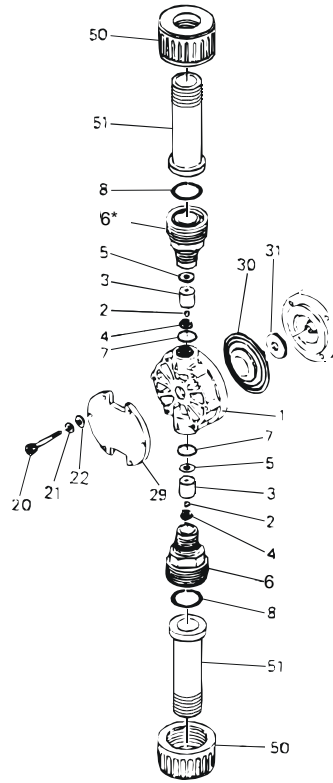

No.	Part	Qty	VC		VH		VS	
			Part No.	Material	Part No.	Material	Part No.	Material
1	Pump head	1	L0770	PVC	L0770	PVC	L1227	PVC
*2	Ball	2	L0063	Alumina Ceramic	L0062	Hastelloy C	L0062	Hastelloy C
*3	Valve guide	2	L0064	PVC	L0064	PVC	L0488	PVC
*4	Valve seat	2	L0066	FKM	L0065	EPDM	L0489	SS304
*5	Valve Gasket	2	L0068	PTFE	L0068	PTFE	L0068	PTFE
6	Adapter	2	L0072	PVC	L0072	PVC	L0072†	PVC
*7	O-ring	2	L0074	FKM	L0073	EPDM	L0073	EPDM
*8	O-ring	2	L0016	FKM	L0015	EPDM	L0015	EPDM

† L0506 (PVC) is used on the suction side.

No.	Part	Qty	Part No.	Material
20	Hex head bolt	6	L0246	SS
21	Split washer	6	EH2010	SS
22	Plate washer	6	EH2011	SS
29	Reinforcing plate	1	L0771	Steel
*30	Diaphragm	1	L0080	PTFE + EPDM
*31	Retainer	1	L0081	SS304
50	Nut	2	L0022	PVC
51	Fitting	2	L1590	PVC

* Parts included in the spare parts kit.

■ LKN45, 47 VC, VH, VS

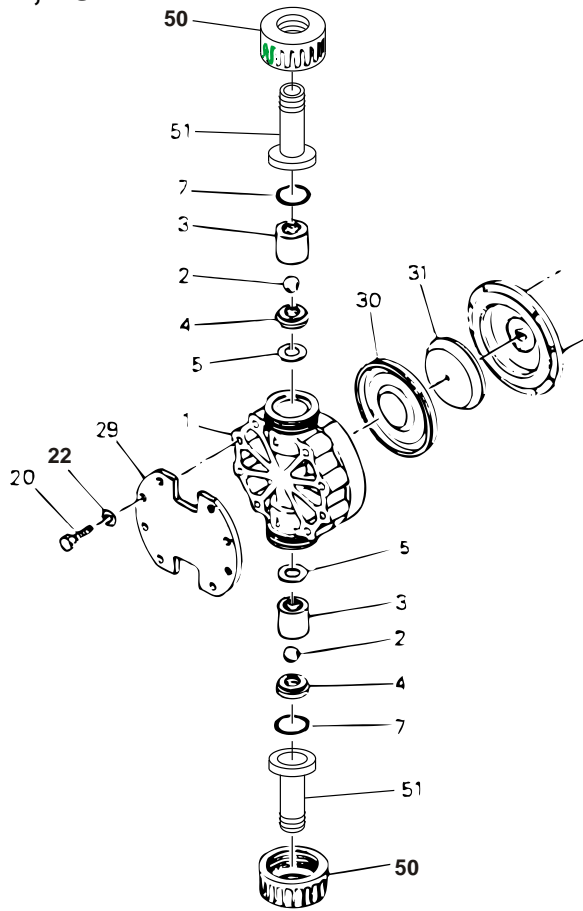

No.	Part	Qty	VC		VH		VS	
			Part No.	Material	Part No.	Material	Part No.	Material
1	Pump head	1	L1500	PVC	L1500	PVC	L1500	PVC
*2	Ball	2	L0093	Alumina Ceramic	L0092	Hastelloy C	L0092	Hastelloy C
*3	Valve guide	2	L0094	PVC	L0094	PVC	L0094	PVC
*4	Valve seat	2	L0095	PVC	L0095	PVC	L0096	SS304
*5	Valve Gasket	2	L0097	PTFE	L0097	PTFE	L0097	PTFE
*7	O-ring	2	L0103	FKM	L0102	EPDM	L0102	EPDM

No.	Part	Qty	Part No.	Material	Notes
20	Hex head bolt	8	L1166	SS	
22	Plate washer	8	L1610	SS	
29	Reinforcing plate	1	L1224	FC200	
*30	Diaphragm	1	L0109	PTFE + EPDM	
*31	Retainer	1	L0110	SS304	
50	Nut	2	L1596	PVC	
51	Fitting, 1/2" NPT	2	L1593	PVC	For LKN45/47-VC/VH and LKN45-VS
51	Fitting, 1" NPT	2	L1595	PVC	For LKN47-Vs only

* Parts included in the spare parts kit.

■ LKN55, 57 VC, VH, VS

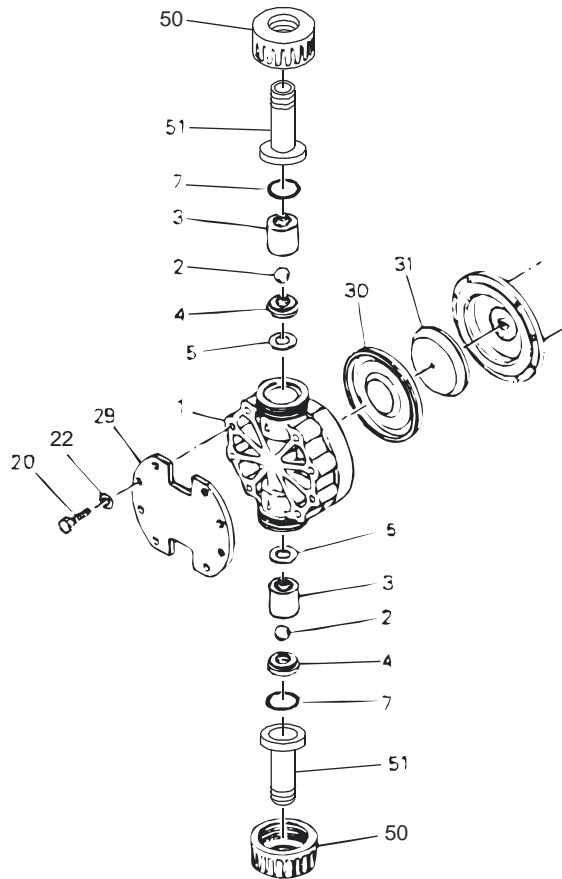

No.	Part	Qty	VC		VH		VS	
			Part No.	Material	Part No.	Material	Part No.	Material
1	Pump head	1	L1513	PVC	L1513	PVC	L1513	PVC
*2	Ball	2	L0151	Alumina Ceramic	L0150	Hastelloy C	L0150	Hastelloy C
*3	Valve guide	2	L0152	PVC	L0152	PVC	L0152	PVC
*4	Valve seat	2	L0153	PVC	L0153	PVC	L0154	SS304
*5	Valve Gasket	2	L0155	PTFE	L0155	PTFE	L0155	PTFE
*7	O-ring	2	L0161	FKM	L0160	EPDM	L0160	EPDM

No.	Part	Qty	Part No.	Material
20	Hex head bolt	8	L1168	SS
22	Plate washer	8	L1610	SS
29	Reinforcing plate	1	L1600	FC200
*30	Diaphragm	1	L0167	PTFE + EPDM
*31	Retainer	1	L0168	SS304
50	Nut	2	L1596	PVC
51	Fitting	2	L1595	PVC

* Parts included in the spare parts kit.

■ LKN32 S6

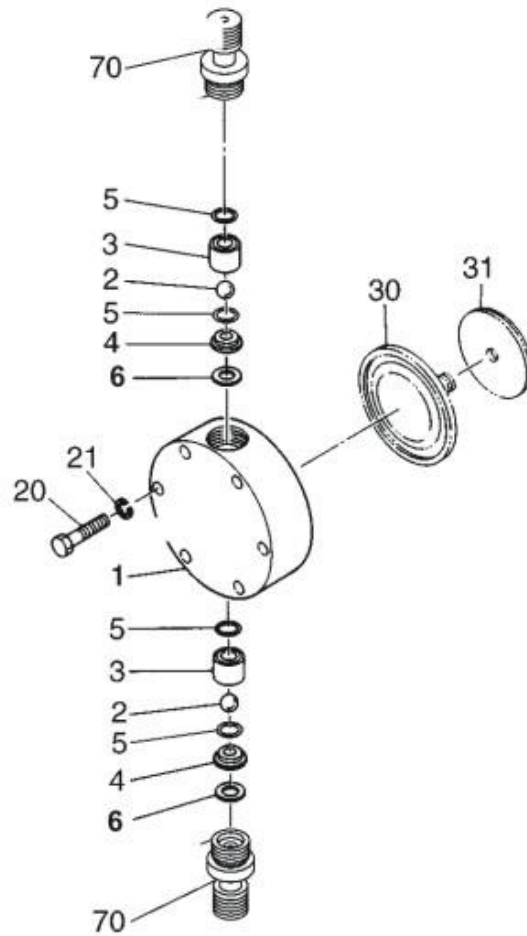

No.	Part	Qty	Part No.	Material
1	Pump head	1	L1204	SS316
*2	Ball	2	L0062	Hastelloy C
*3	Valve guide	2	L1205	SS316
*4	Valve seat	2	L1206	SS316
*5	Valve gasket A	4	L0244	PTFE
*6	Valve gasket B	2	L0245	PTFE
20	Hex head bolt	6	L0246	SS
21	Split washer	6	EH2010	SS
22	Plate washer	6	EH2011	SS
*30	Diaphragm	1	L0080	PTFE + EPDM
*31	Retainer plate	1	L0081	SS304
70	Fitting	2	L1592	SS316

* Parts included in the spare parts kit.

■ LKN45, 47, 55, 57 S6

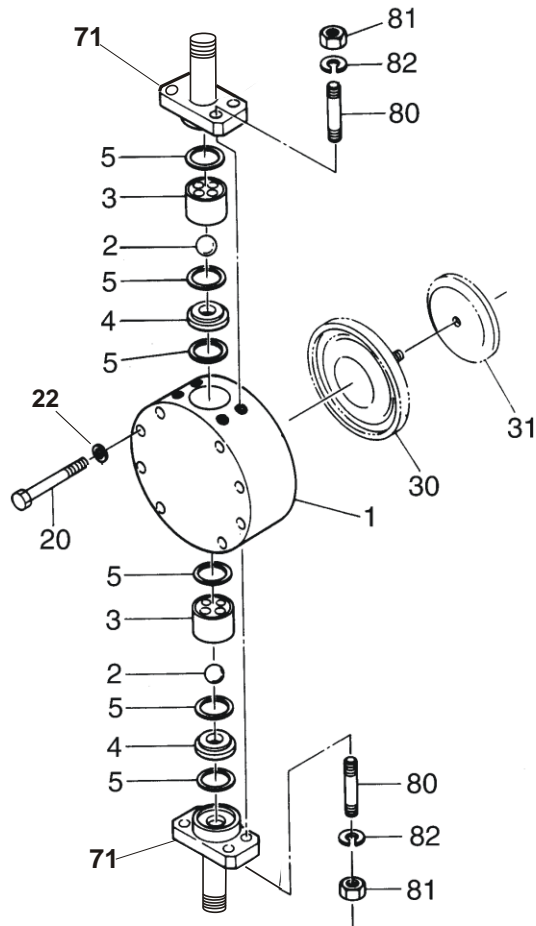

No.	Part	Qty	Part No. for LKN45, 47	Part No. for LKN55, 57	Material
1	Pump head	1	L1209	L1212	SS316
*2	Ball	2	L0092	L0265	Hastelloy C
*3	Valve guide	2	L0826	L1213	SS316
*4	Valve seat	2	L0827	L1214	SS316
*5	Valve Gasket	6	L0257	L0269	PTFE
20	Bolt w/split washer	8	L1167	L1167	SS
22	Plate washer	8	L1610	L1610	SS
*30	Diaphragm	1	L0109	L0167	PTFE + EPDM
*31	Retainer plate	1	L0110	L0168	SS304
71	Fitting	2	L1594	L1599	SS316
80	Stud bolt	8	L1509	L1518	SS
81	Hex nut	8	L0762	L1523	SS
82	Split washer	8	L1512	L0189	SS

* Parts included in the spare parts kit.

■ LKN32 TC

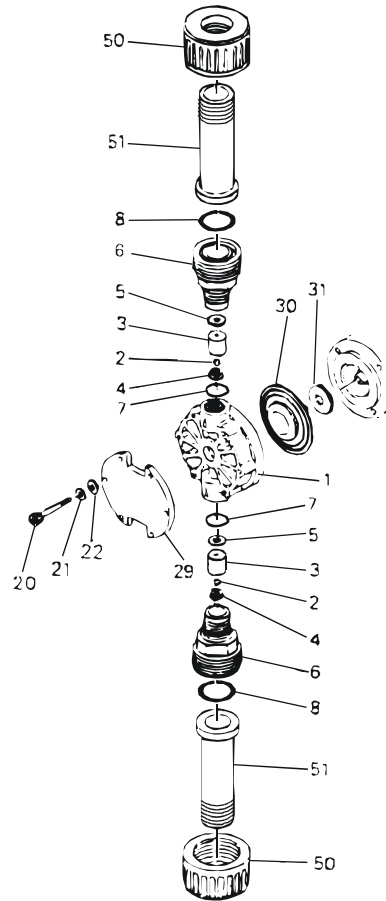

No.	Part	Qty	Part No.	Material
1	Pump head	1	L1226	PVDF
*2	Ball	2	L0063	Ceramic
*3	Valve guide	2	L0332	PVDF
*4	Valve seat	2	L0066	PVDF
*5	Valve Gasket	2	L0068	PTFE
*6	Adapter	2	L0335	PVDF
*7	O-ring	2	L0074	FKM
*8	O-ring	2	L0016	FKM
20	Bolt	6	L0246	SS
21	Split washer	6	EH2010	SS
22	Plate washer	6	EH2011	SS
29	Reinforcing plate	1	L0771	SS41
*30	Diaphragm	1	L0080	PTFE + EPDM
*31	Retainer plate	1	L0081	SS304
50	Nut	2	L1611	PVDF
51	Fitting	2	L1591	PVDF

* Parts included in the spare parts kit.

■ LKN45, 47 TC

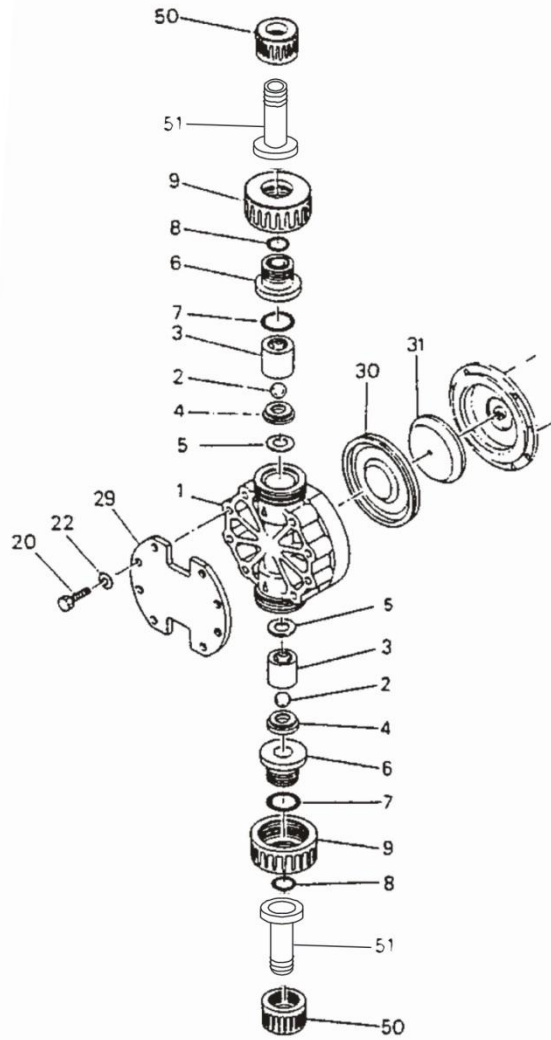

No.	Part	Qty	Part No.	Material
1	Pump head	1	L1505	PVDF
*2	Ball	2	L0093	Ceramic
*3	Valve guide	2	L0347	PVDF
*4	Valve seat	2	L0348	PVDF
*5	Valve Gasket	2	L0097	PTFE
6	Adapter	2	L0350	PVDF
*7	O-ring	2	L0103	FKM
*8	O-ring	2	L0016	FKM
9	Nut	2	L1539	PVDF
20	Bolt w/split washer	8	L1166	SS304
22	Plate washer	8	L1610	SS
29	Reinforcing plate	1	L1224	SS41
*30	Diaphragm	1	L0109	PTFE + EPDM
*31	Retainer plate	1	L0110	SS304
50	Nut	2	L1611	PVDF
51	Fitting	2	L1591	PVDF

* Parts included in the spare parts kit.

■ LKN55, 57 TC

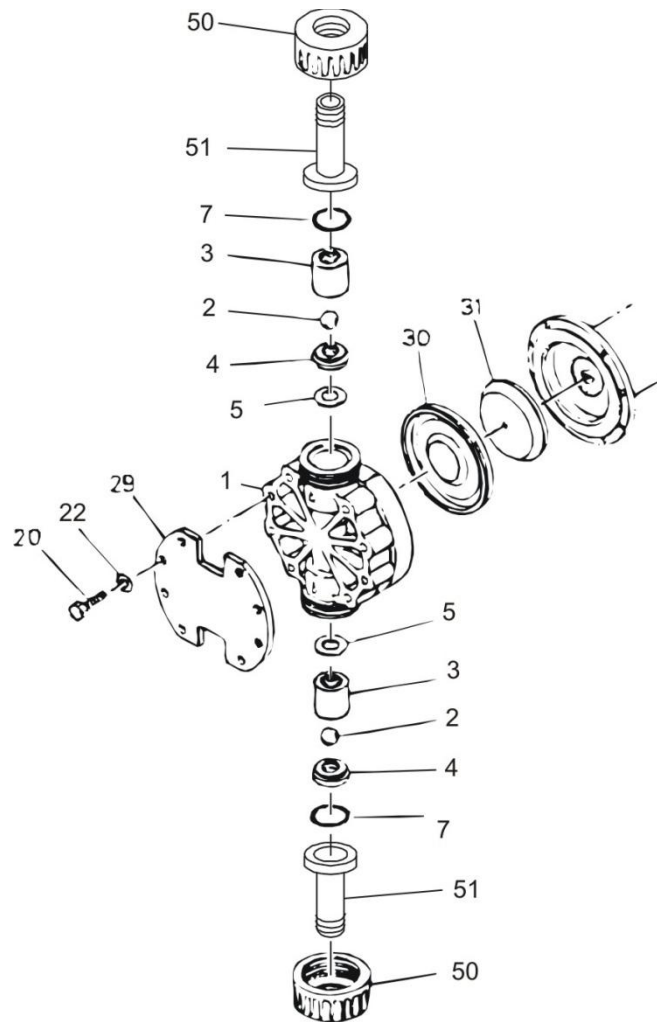

No.	Part	Qty	Part No.	Material
1	Pump head	1	L1521	PVDF
*2	Ball	2	L0151	Ceramic
*3	Valve guide	2	L0363	PVDF
*4	Valve seat	2	L0364	PVDF
*5	Valve Gasket	2	L0155	PTFE
*7	O-ring	2	L0161	FKM
20	Bolt w/split washer	8	L1168	SS304
22	Plate washer	8	L1610	SS
29	Reinforcing plate	1	L1600	FC200
*30	Diaphragm	1	L0167	PTFE + EPDM
*31	Retainer plate	1	L0168	SS304
50	Nut	2	L1598	PVDF
51	Fitting	2	L1597	PVDF

* Parts included in the spare parts kit.

5 Description on Main Unit and Label

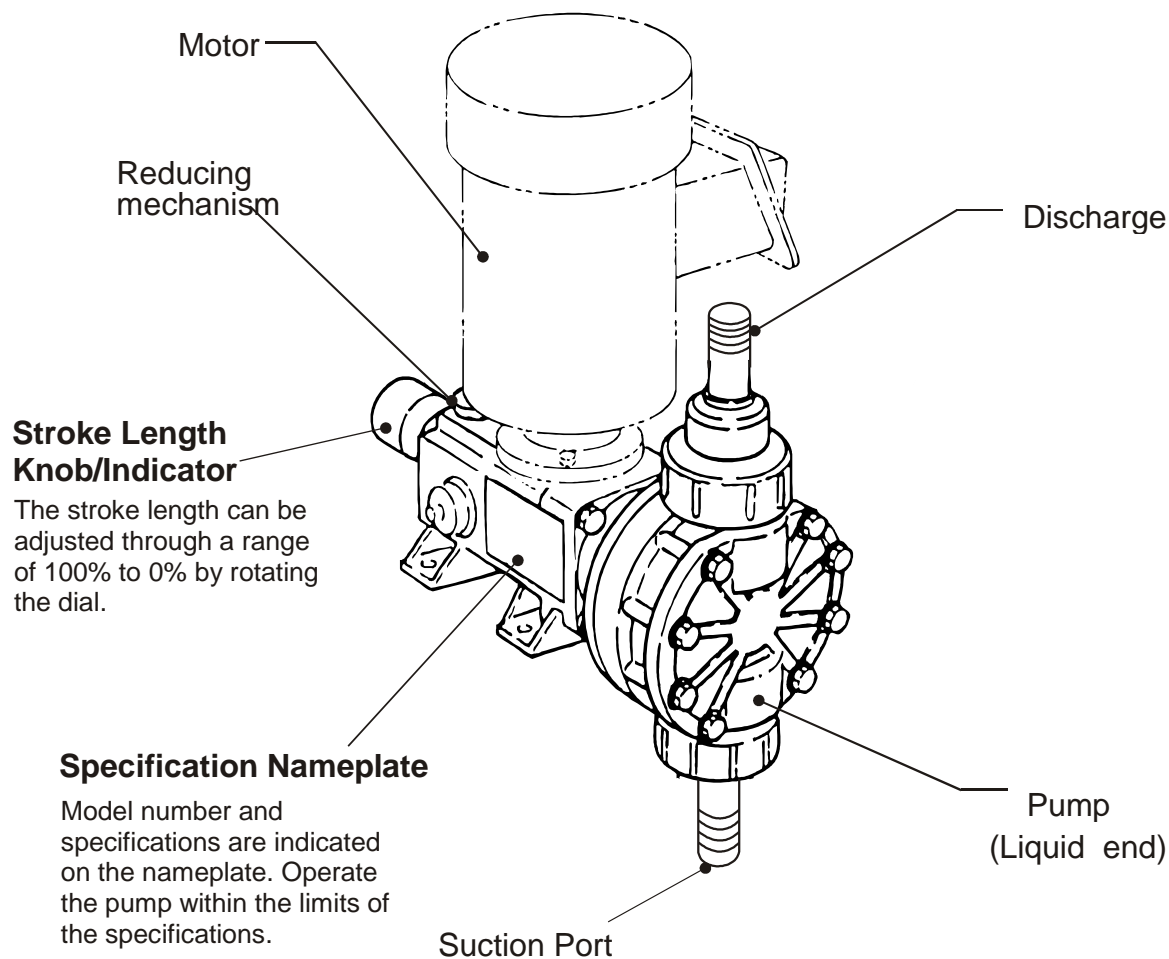

Caution: Do not use any solvent when wiping the nameplate, labels or the pump main unit.

6 Handling Instructions



Warning

Do not operate the pump with dangerous or hazardous mediums (such as explosive, combustible, flammable, or toxic substances).



Caution

Read the following information prior to installation of the pump:

■ **Protective gear:**

When operating the pump or working near it, always wear protective clothing, face guard, goggles, and gloves. Further precautionary measures must be taken depending upon the type of liquid used.

■ **Pump repair:**

Do not try to disassemble or repair the pump beyond the range specified in this instruction manual. Contact the local distributor for further help.

1. Handle the pump carefully.
Impacts caused by dropping the pump on the floor or striking it may result in damage or faulty performance.
2. Do not operate the pump under the following condition:
 - where the temperature falls below 0°C
 - where corrosive gas or explosive gas may be present
 - exposed to splashing water
 - where the ambient temperature is 40°C or above
 - where the humidity is excessively high (Permissible humidity: 35~85%RH)
 - places filled with or likely to be filled with explosive or corrosive atmosphere
 - danger due to dust, fire, earthquake and/or any externally imposed shock
3. Keep the pump away from fire.
To prevent fire and explosions, do not place dangerous or flammable substances near the pump.
4. Damaged pump or motor
Do not operate a damaged pump due to the possibility of electric shock.
5. Pump modification
Never attempt to modify the pump. This may cause a serious accident or damage.
6. No disassembly or repair
Users should not disassemble and repair the pump beyond the level given in the "Disassembly and Assembly" section of this manual.



Caution

The pump must be repaired by trained and qualified operators only. If in need of repair, stop operation and contact your supplier for service.

7. Do not close the discharge or suction lines while in operation.
Pump operation with valves closed increases the load onto the pump itself and will eventually damage the pump or piping.
8. Do not adjust the stroke length while the pump is not operating.
Rotating the stroke adjustment dial while not in operation applies load onto the dial and will eventually damage the pump.
9. Allowable pressure limit
Set the discharge pressure at or below the allowable pressure limit level indicated in the “Specifications” section.
10. Temperature/humidity fluctuation
Temperature fluctuation may not affect the performance of the pump itself. However, the liquid may change in terms of its viscosity, pressure, or corrosion resistance. Pay special attention to changes in liquid characteristics as a result of temperature fluctuation.

Liquid temperature range:	
Material symbol VC, VH, VS:	0~50°C
Material symbol S6, TC:	0~80°C
Ambient temperature range:	0~40°C
Humidity range:	35~85%RH

7 Installation

1. Installation position
 - Install the pump as close to the suction tank and as low as possible. Flooded suction is the ideal installation.
 - The suction lift ability depends upon the liquid properties, temperature, and length of the suction piping. For details of the setup, consult your distributor.
2. Indoor and outdoor use
 - The pump can be operated either indoors or outdoors. However, safety measures should be taken so as not to expose the motor and power distribution unit to flooding and it is always, recommended that the pump be shielded from direct exposure to the elements (snow, direct sun, etc.).
3. Installation site
Select an installation site that is flat and free of vibrations caused by nearby machines. Sufficient space for maintenance should be provided.

■ **Lifting**

Lift the pump horizontally so that the gear oil will not leak out of the pump drive unit.

■ **Foundation preparation (before pump installation)**

1. The area for anchoring the pump should be greater than the area of the pump base. If the anchoring area is too small, the base may be destroyed due to the concentrated load on it.
2. If pump operation is to be subject to vibration (resonance with the piping, for example), provide an expansion joint between the pump and the piping. Otherwise, the piping, gauge, etc., may be damaged.
3. Installation advice
 - Use anchor bolts to fasten the pump base firmly.
 - Install the pump horizontally.
 - Sufficient space is required to allow cool air from the motor fan to circulate.
 - Allow ample space around the pump for easy and efficient maintenance work.

8 Piping

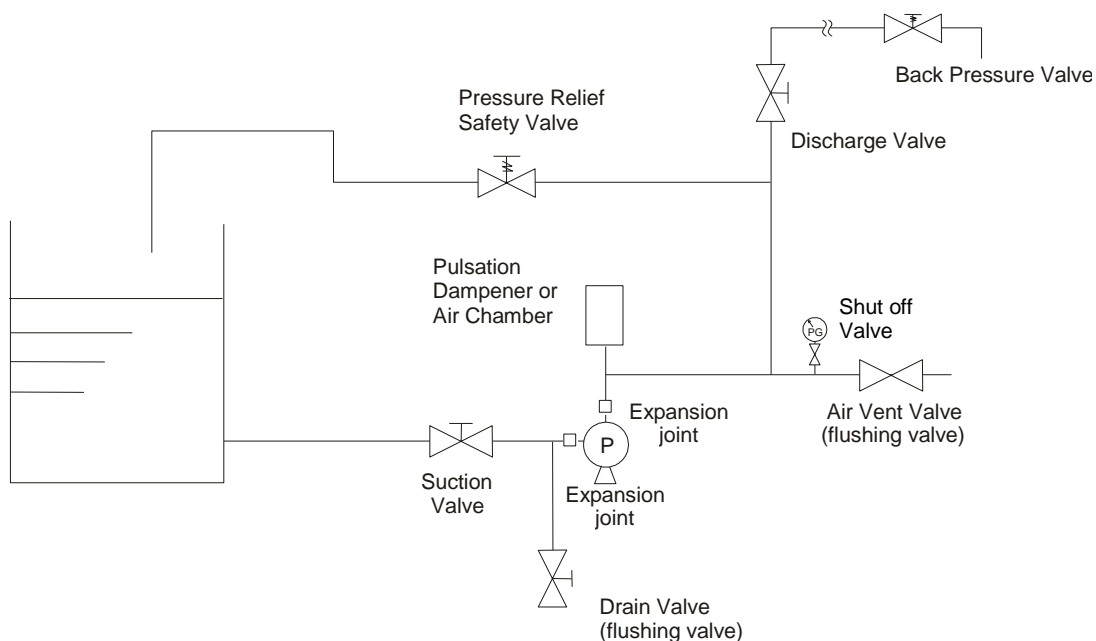

■ **Load of piping for LK-N**

When plumbing the pump, support the piping and use an expansion joint so as not to apply a load onto the pump discharge/suction ports.

■ **General precautions**

1. All piping should be supported independently so that unnecessary weight and vibration are not transmitted directly to the pump. Expansion joint is recommended to avoid damaging the pump head especially.

2. The best piping arrangement for minimum pressure loss is achieved with straight runs and full bore piping containing as few bends and fittings as possible.
3. When handling a high or low temperature liquid, provide an expansion joint in the pipeline to allow for stress caused by thermal expansion and contraction.
4. When handling a slurry liquid, provide a drain plug at the bottom of the piping and do not make a “trap” in the piping system.
5. When handling a viscous, toxic or a liquid that easily crystallizes, install piping for cleaning.
6. Use adequate piping materials that can resist pressure and corrosion.
7. Clean the inside of pipes before installation. Remove the caps fitted on the pump inlet and outlet before installing piping. The caps are provided for preventing contamination by foreign matter.
8. A pressure relief safety valve and a pulsation dampener should be installed on the discharge line near the pump.



CAUTION! Operation without a pressure relief safety valve installed could result in catastrophic failure and a dangerous condition if the discharge line is closed for any reason during operation

■ ***Suction piping***

1. Flooded suction is always recommended.
2. The diameter of the suction pipe should never be smaller than the size of the pump inlet.
3. The suction piping should be as short as possible. Excessive length may lead to flow restriction, cavitation and damage to the pump.
4. Air ingress from the joints in the piping system may cause pumping damage or inconsistent flow. Make sure the joints are well sealed.

■ ***Discharge piping***

1. Install a pressure relief safety valve as close to the pump discharge as possible. Its setting pressure should not exceed the pressure permissible for the pump and pipes.
2. Maintain pipe diameter (match pump discharge size) through discharge point including all valves and injectors. At a minimum, match size through pressure relief valve to ensure safety and protect the pump.
3. Firmly connect and seal all the joints using proper pipe support (this includes flexible tubing as pulsation and tubing flex can stress pump head connection).
4. Install a pressure gauge on the discharge piping to verify actual pressure in discharge. The pressure gauge must be installed before any pipe reductions to measure an accurate pressure to the pump.

5. Install a pulsation dampener (air chamber or accumulator) in the discharge piping to prevent any fluctuation of pressure. Install the pulsation dampener in a position close to the pump discharge port. A pulsation dampener will significantly increase the life of the pump.

9 Wiring

■ *Electrical connections*



WARNING

The electrical connection should be carried out by an authorized electrician in accordance with local regulations. Please make sure that the electrical data on the nameplate of the motor corresponds to the electrical supply on which it will be used. Motors must be connected to a motor protection switch.

1. Use an electromagnetic switch that conforms to the specifications (voltage, capacity, etc.) of the pump motor.
2. If using the pump outdoors, waterproof the wiring to protect the switches from rainwater.
3. Electromagnetic switches and push buttons should be installed at a reasonable distance from the pump.

10 Operating Instructions

1. Never operate the pump with the suction and discharge side valve closed. Otherwise, the inside of the pump or the piping will be damaged.
2. In the event of a service power failure, turn off the power switch immediately and close the discharge valve.
3. **Maximum pump surface temperature (not motor)**
The max. pump surface temperature of each model is shown in the table. Arrange protective measures in accordance with the temperature levels.

Model	Liquid temp °C	Max. surface temp. at 40°C ambient temp °C
LKN32, 45,47,55,57 VC, VH, VS	50	45
LKN32, 45,47,55,57, S6	80	75

4. Sound generated by pump

The level of sound generated by LKN type of pump is 85 (dB). Arrange a muffling device to reduce the sound level if necessary. The procedure for sound measurement conforms to the EN 31201 (ISO11201).

■ **Preparation for start-up**

The following inspections should be made before the initial operation after installation and operation after a long period of inactivity.

1. Thoroughly clean the inside of the tank and pipe. Then, supply liquid.
2. Tighten the pump connections and the installation bolts on the base.
3. Check every part of the pump for defects, loosened bolts, oil leakage, etc.
4. Check the oil gauge to see if the drive unit is filled with the specified amount of oil.

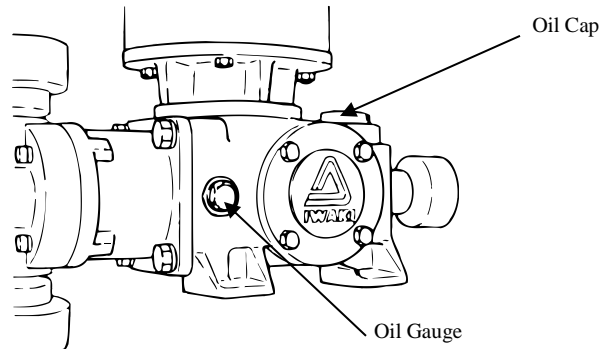

5. Run the motor instantaneously to check for correct direction of motor rotation. The motor should run in the direction indicated with the arrow on the pump. If the direction is reversed, rewire the motor power wires in accordance with the wiring schematic on the motor nameplate.

■ **Operation**

1. Open the valves of the suction and discharge pipes.



Caution
DO NOT OPERATE THE PUMP WITH THE VALVES CLOSED.

2. Provide power to the motor.
3. Loosen the hex socket head bolt of the stroke length dial. Set the stroke length to 0% by turning the stroke length dial clockwise



Caution
DO NOT TURN THE DIAL WHILE THE PUMP IS NOT OPERATING.

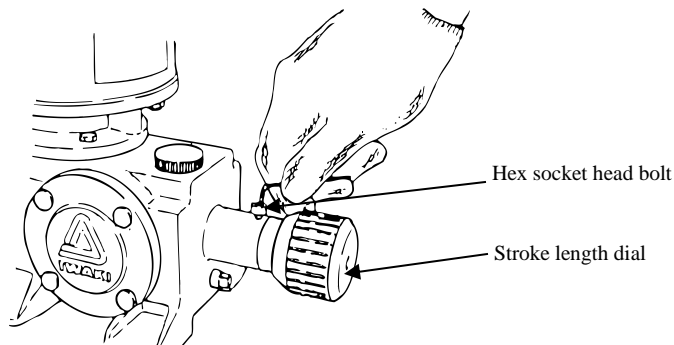

4. Continue to run the pump for 30 minutes or longer to let it warm up. Check that no abnormality is found. This procedure is necessary only during the first operation, but when the ambient temperature is extremely low, continue no-load running until the oil temperature rises sufficiently because the motor may sometimes be overloaded a little due to an increase in the viscosity of oil in the drive unit.
5. Open an air vent valve to purge the discharge line of air.
6. Increase the stroke length up to 100% and continue to run the pump for 30 minutes or longer again.
7. Close the air vent valve gradually, watching the pressure gauge. The liquid will come into the discharge line and be discharged from the end of the pipe. Should the discharge pressure exceed the permissible pressure for the pump before the air vent valve is completely closed, check the piping system.
8. Check that the motor amperage does not exceed the rated value and that no abnormality is found.

■ **Metering and Calibration**

1. Operate the pump using the actual liquid and installation conditions.
2. Setting the stroke length at 100%, determine the discharge capacity per minute several times. If no noticeable variation is found after repeated measuring, the pump is working normally.
3. Measure the discharge capacity at two or three points of the stroke length. When a set point is changed, measure the discharge capacity after running one minute or longer.
4. Plot a pump calibration curve using the results of the above procedures.
[Note] Our in-plant test data is based on pumping water at normal ambient temperature with a short piping system. Therefore, there will be a difference between the test data and the practical performance data.
5. The relationship between the amount of stroke length dial revolution and stroke length is shown in the following graphs.

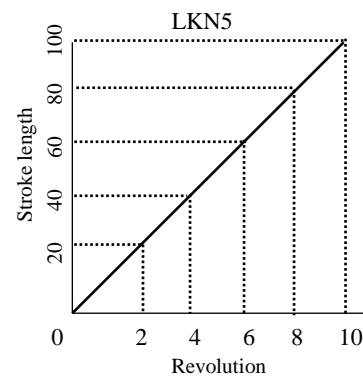
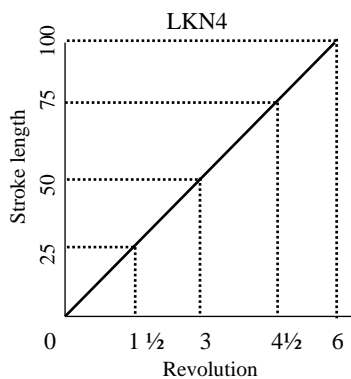
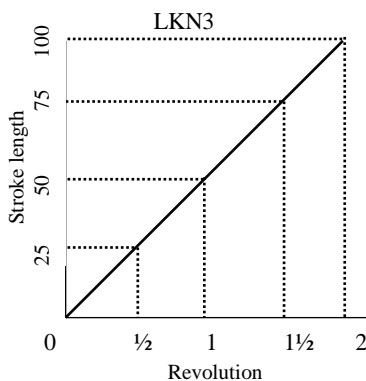

■ ***Starting after the pump is stopped or out of use***

1. When the pump is stopped for a short period of time (within a week), it can be re-started at its prescribed pressure and capacity.
2. When the pump has been out of use for a long period of time, operate the pump at zero pressure for a few minutes to lubricate it thoroughly. Do not start the pump at a prescribed pressure immediately.

■ ***Pulsation dampener***

It is always recommended to install a pulsation dampener, i.e. diaphragm type accumulator, air chamber, etc. Because a metering pump is a reciprocating device, it produces pressure pulsations that the system sees in the form of acceleration, inertia, shock, noise, and reduced service life. When the piping is long, it is especially important to use a pulsation dampener for accurate metering.

11 Troubleshooting

Item	Problem	Ref. No. for Cause/Countermeasure
A	Discharge capacity is low.	1, 2, 4, 5, 6, 7, 8, 9, 11, 12
B	Discharge capacity is excessive.	3, 7, 9
C	Discharge capacity is unstable.	1, 2, 3, 4, 5, 7, 8, 11, 12
D	No liquid is discharged.	1, 2, 4, 7, 8, 11, 12
E	Discharge pressure does not increase.	1, 2, 4, 8, 10, 11, 12
F	Pump will not prime.	1, 2, 4, 5, 6, 7, 8, 12
G	Liquid leaks.	5, 6
H	Motor does not run.	15, 16, 17, 18, 19
I	Motor draws excessive amperage.	13, 15, 16, 17, 19
J	Excessive vibration and loud noise.	8, 12, 13, 15, 19
K	Oil leaks.	14
L	Gearbox temperature is excessive.	7, 13, 19

Ref.	Cause	Countermeasure
1	Foreign matter is clogging valve ball, valve seat and/or valve guide.	Disassemble and clean.
2	Valve seat and/or valve ball is worn.	Replace.
3	Differential pressure is inadequate.	Install a back-pressure valve in discharge line. (5 PSI is required as min. differential pressure.)
4	Air leaks into suction line.	Inspect suction pipes and connections. Re-tighten.
5	Defective valve gasket or O-ring	Replace.
6	Damage to diaphragm	Replace. Check the discharge pressure for foreign matter or crystallization in the pump chamber if it fails prematurely.
7	Pumping condition (liquid, temperature, pressure, piping, etc.) changes.	Renew pump performance data of the altered pumping condition after confirming that the pump is good.
8	Suction pipe or strainer is clogged.	Disassemble and clean.
9	Stroke length dial has moved.	Readjust and tighten lock bolt securely after confirming that no liquid is discharged at stroke length of 0%.
10	Dust is clogging mouth of pressure gauge or pressure gauge is defective.	Clean or replace.
11	Leak from safety valve	Readjust pressure setting or replace if it is defective.
12	Cavitation occurs due to insufficient NPSHr.	Examine suction conditions.
13	Lubricating oil of the drive unit is not correct.	Check that the correct oil has been used. Check the oil quantity and level. Replenish or replace if necessary.
14	Defective oil seal or O-ring	Replace.
15	Defective motor	Replace.
16	Wrong wiring or defective contact	Check wiring. Replace switch, etc. if necessary.

Ref.	Cause	Countermeasure
17	Voltage drop	Inspect cause and take countermeasures accordingly.
18	Blown fuse.	Inspect cause and take countermeasures accordingly.
19	Overload (excessive discharge pressure)	Check discharge line and take countermeasures to lower the pressure.

12 Maintenance and Inspection

■ Daily inspection

1. Check whether the pump operates smoothly and without any abnormal noise or vibration.
2. Check the level of the liquid in the solution supply tank.
3. Check the pump and piping for leakages.
4. Check the drive unit for oil loss and leakage.
5. Compare the discharge pressure and electric current measured during operation with the values indicated on the motor nameplate for verification of normal pump load.
 - Note that the values indicated on the pressure gauge vary in proportion to the specific gravity of the liquid. The valve to the pressure gauge must be opened only when measurement is carried out. It must be closed upon the completion of each measurement. If the valve remains open during pump operation, the meter mechanism in the gauge may be affected or damaged by noise or vibration.
6. If a spare pump is available, activate it from time to time to keep it ready for use any time. Check to be sure there are no leaks from the pump before operating it. If leakage is detected, never try to operate the pump.
7. Check to be sure the discharge pressure, discharge flow rate, and motor power supply voltage do not fluctuate during pump operation. If considerable fluctuation is observed, refer to the Troubleshooting section for corrective measures.

■ Periodic inspection

To ensure efficient and smooth operation of the pump, periodically inspect the pump and installation. When inspecting, overhauling, or if repair is necessary, stop the pump operation and contact the supplier as necessary.

The overhauling and repair work for Iwaki America pumps must be performed by qualified personnel who have been trained and certified by the pump supplier. User's failure to observe this instruction exempts Iwaki America from the responsibility for personal injury or damage to the equipment or facility that result from its misuse.

1. Valve Unit

Check the valve balls, valve seats and valve guides every 6 months. If flaws or worn parts are found, replace them.

2. Diaphragm

Check the diaphragm every 6 months if the usage is fairly light. The life of the diaphragm depends on the characteristics, pressure, temperature, etc. of the liquid being pumped. If any deformation or crack is found, the diaphragm should be replaced with a new one.

3. Oil

Change the oil in the drive unit once a year. If emulsification of the oil is found during inspection, immediately change the oil. Remove the drain plug and drain the drive unit. Flush the inside with oil to clean it. Then, add new oil up to the specified level of the oil gauge. Ensure any replacement oil is SAE (80W-90) and must exceed API Service GL-4.

Model	Oil Qty	Recommended Oil
LKN	7.44oz (220 mL)	Esso (Exxon) GP80W-90, Shell Spirax/EP80, Mobil Pegasus Gear Oil 80 (Automobile Gear Oil SAE-80, API Grade GL-4), Castrol Hypoy Gear Oil

Contact your Iwaki America distributor if the oil listed above is unavailable. Use of incorrect oil may shorten the life-term of the gear unit.

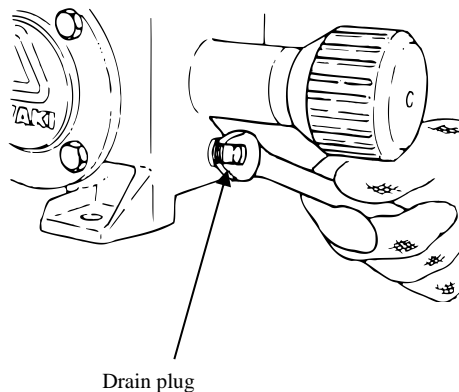

13 Spare Parts

If downtime is critical, it is recommended to always maintain a stand-by pump and a spare parts kit if the pump is being used continuously.

Recommended Spare Parts	Estimated Service Life
Valve, Valve guide, Valve seat	12 months (life is dependent on the characteristics of liquid being pumped)
O-ring and Gasket	12 months (o-rings and gaskets shall be replaced at each disassembly)
Diaphragm	4,000 hrs (life is dependent on the discharge pressure, liquid, temperature, etc.)
Drive unit	3 years

Note: The above service life figures are only estimates and not a guarantee. Actual application will determine pump life.

14 Disassembly and Assembly

Refer to exploded view of the model corresponding to your pump. The views are shown in Section 4 – Exploded View and Parts List.



Caution

- Before disassembling/assembling the pump, to turn off the main power supply. Display a “WORKING” sign near the power switch to let other personnel know the situation. Accidental power ON initiated by an other person may result in an accident. The operator must take special precautions to prevent this situation.
- Prior to disassembly or assembly, close the suction valve and discharge valve fully.
- The piping and the pump often retain liquid. When working around a dangerous liquid, wear appropriate protection (goggles, rubber gloves, etc.) when disconnecting the pipes and decontaminating the pump.

■ **Disassembly**

1. Disassemble only after thoroughly decontaminating the pump by flushing and cleaning the piping and the inside of the pump.



Warning

Wear protection (goggles, rubber gloves, etc.).
Certain liquids are dangerous and may hurt your eyes and skin.

2. Remove the discharge and suction piping.



Caution

Close the suction valve and discharge valve fully, prior to removing the discharge and suction piping.

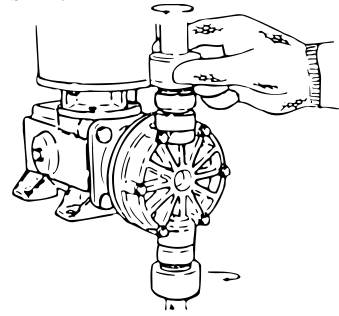

• **Valve**

1. Remove the suction and discharge fitting by loosening the nut (50).
Remove the adapter (6) if any, and take out the valve (2), valve guide (3), valve seat (4), valve gasket (5) and O-ring (7). If the pump head is made of stainless steel, the valve assembly can be taken out by loosening the setting flange (54) or the nuts (81).
2. Check the valve and valve seat. If they are damaged or worn, replace with a new ones. It is highly recommended to replace the gasket and O-ring every time the liquid end is disassembled.

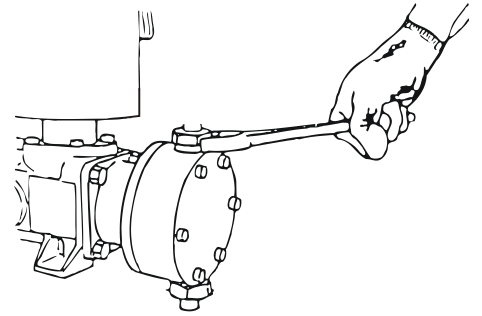

• **Diaphragm**

1. Loosen the hex head or socket head cap bolts (20).
2. Remove the pump head (1).
3. Connect power supply and run the motor temporarily (without the liquid end).
Set stroke length to 100%. Turn off when the diaphragm comes to the top dead center (when the diaphragm is most extended).
Disconnect power supply.



Caution

Do not touch any moving parts during operation.

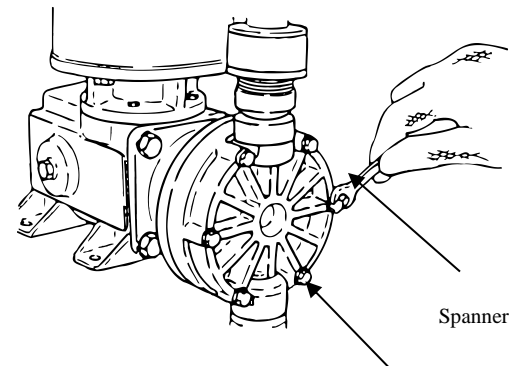

Hex head bolt (20)

4. Remove the diaphragm from the pump shaft by turning the diaphragm counterclockwise with hand. If it is worn or deformed part in any way, replace it with a new one

5. Attach the new diaphragm firmly to the pump shaft by turning it clockwise by hand (hand tighten only, no tools). Confirm that the retainer (31) is sitting correctly around the diaphragm insert bolt and rests against the end of the pump shaft. If the position of the pump shaft moves during reassembly of the diaphragm, set it at top dead center, following the above procedure #3.

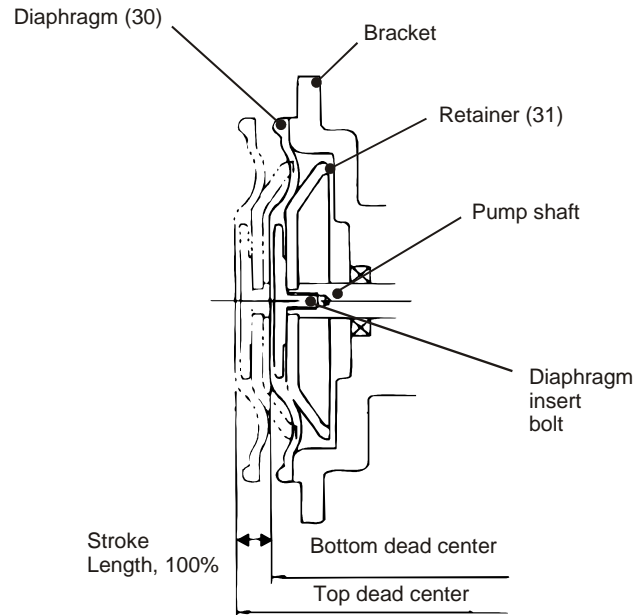

■ **Assembly**

The pump should be assembled by carrying out the steps of disassembly in reverse. Pay special attention to the following points:

• **Valve**

1. Replacement of o-ring and gasket
Replace the o-ring or gasket, with a new one. Additionally, ensure that the o-ring or gasket is not twisted or pinched between parts.
* The sealing section should be free of dust or scratches before installation.
2. Assemble the valve assembly by reversing the procedure, taking special care with the direction and position of the valve guide, valve seat and valve gasket.



Caution

If the direction or position of the valve guide, valve ball, or valve seat is incorrect, the pump will not pump and/or may be damaged.

- When installing the LKN32 fitting/nut (VC, VH, or VS type), use a spanner wrench to hold the adapter (6) then fasten the nut (50) by hand.

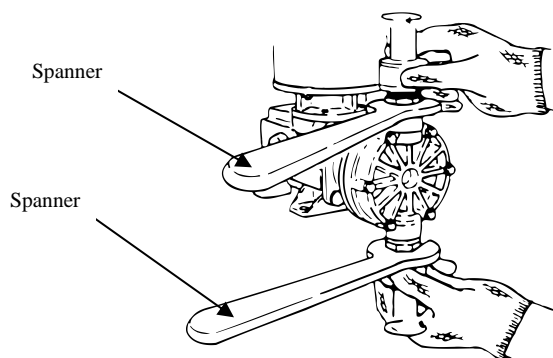

- Diaphragm**

- Connect power supply and temporarily run the motor, moving the diaphragm to the bottom dead center where the diaphragm is fully drawn back. Turn off motor.



Caution

Only attach the head when the diaphragm is at bottom dead center. Premature diaphragm failure may occur if this step is not observed.

Do not touch any moving parts during operation.

- Fit the pump head (1) to the bracket of the drive unit with the hex head or socket head cap bolts (20). Tighten all the bolts securely and uniformly.

Tightening torque for bolts (20)

	LKN 32	LKN 45, 47	LKN 55, 57
VC, VH, VS, TC	27 in-lbs (3.0 Nm)	106 in-lbs (12.0 Nm)	106 in-lbs (12.0 Nm)
S6	44 in-lbs (5.0 Nm)	106 in-lbs (12.0 Nm)	106 in-lbs (12.0 Nm)

Five Boynton Road Hopping Brook Park Holliston, MA 01746 USA TEL 508-429-1440 FAX 508-429-1386
www.lwakiAmerica.com