

Motor-Driven Metering Pump

LK Series metering pumps are motor-driven, mechanically actuated diaphragm metering pumps with a maximum capacity of 114 GPH (432 l/h) and a maximum pressure of 225 PSI (1.5 MPa). The LK Series is ideal for chemical feed applications in a wide range of fields, including water treatment, chemical process, agriculture, mining and paper.

- **Liquid Ends** - Drive from the gear reduction unit is directly transferred to the diaphragm. This design is economical, yet retains a high degree of versatility. Liquid ends are available in PVC, PVDF and 316 SS for handling acids, bases, solvents, polymers and slurries.
- **Stroke Adjustment** - Accurate and reliable stroke setting is accomplished with a micrometer dial of the springback stroke adjustment mechanism. This lockable mechanism is adjustable from 10 to 100%.
- **Drive** - The LK utilizes a dual-cam system drive with a built-in worm gear type speed reducer. The aluminum bronze worm gear and the tapered roller bearing provide efficient transmission of motor power to the pump. This compact and rigid mechanism provides maximum wear resistance in continuous operation over long periods of time.
- **Motors** - All of the standard models employ totally enclosed fan-cooled motors which are vertically mounted to save space. A variety of motor options are available, including explosion-proof and DC variable speed motors for external control by a 4-20 mA input signal..



Model Identification Code

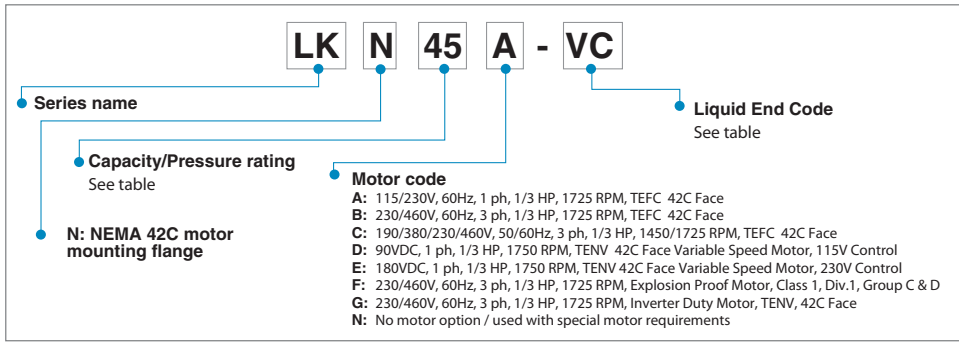

Material codes

- PVDF: Polyvinylidene fluoride
- CE: Ceramic
- FKM: Fluoroelastomer
- EPDM: Ethylene propylene diene monomer
- HC: Hastelloy C276

Liquid End Code

Type	VC	VH	VS	TC	S6	
Application	Acids	Alkalines	Viscosity & Slurry	Stron Acids	Solvents	
Pump head	PVC			PVDF	SS316	
Valve ball	CE	HC	HC/SS304	Alumina Ceramic	HC	
Valve seat	Type 32	FKM	EPDM	SS304	FKM	SS316
	Type 45 to 47	PVC	PVC	SS304	PVDF	SS316
O-ring	FKM	EPDM	EPDM	FKM	----	
Valve gasket	PTFE					
Diaphragm	PTFE + EPDM					

Capacity/Pressure Rating

Model	Capacity*		Max Pressure PSI (MPa)		Stroke Speed SPM		Connection	Weight*** lbs	
	50 Hz LPH	60 Hz GPH	PVC/PVDF	SS	50 Hz	60 Hz		PVC/PVDF	SS
LKN32	30	9.5	150 (1)	225 (1.5)	96	116	1/2"	50	61
LKN45	50	15.9	150 (1)	225 (1.5)	48	58	1/2"	55	70
LKN47	100	31.8	120 (0.8)	120 (0.8)	96	116	1/2"***	55	70
LKN55	168	53.4	75 (0.5)	75 (0.5)	48	58	1"	59	81
LKN57	360	114.3	45 (0.3)	45 (0.3)	96	116	1"	59	81

* Capacities listed are at Max. pressure.
 ** LKN47 with VS liquid end has 1" NPT connections
 *** Weights with standard motor

- Iwaki America recommends the installation of a pressure relief valve and a pulsation dampener in the discharge line of LK pumps. Contact your IA distributor for these and other accessories.
- Maximum viscosity at rated output is 1000 cps for VS and S6, 500 cps for VH and 300 cps for VC and TC.
- It is recommended that pumps be shielded from direct exposure to the elements.

Dimensions (Shown with optional base (E00099))

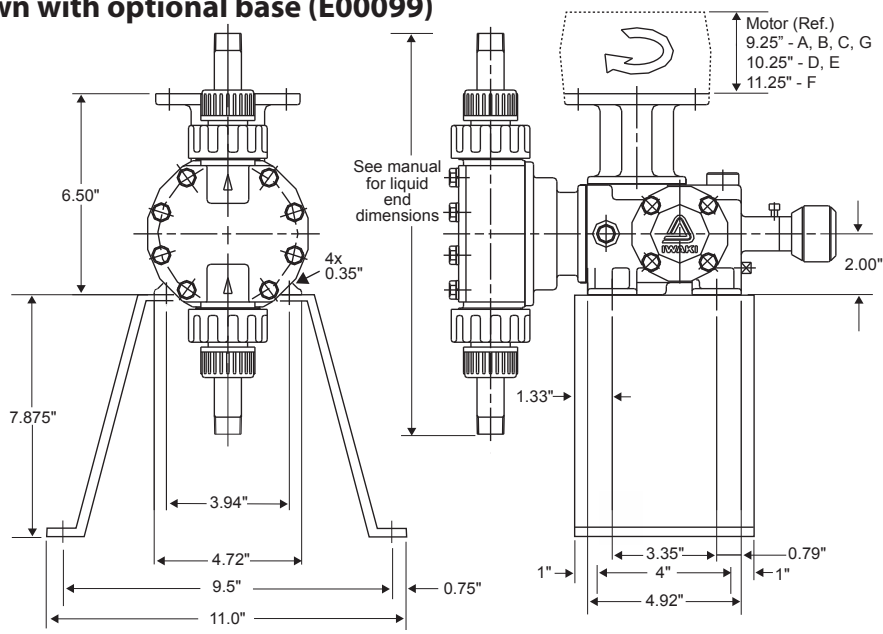

IALT-00043.G July 2014



www.IwakiAmerica.com