

## MDM-3158 7.5-50 HP

- Non-contact Bearing System allows dry run operation (CF models only)
- Simple, rugged design
- Corrosion resistant ETFE internals
- Spline/pinned impeller design provides positive locking of impeller/inner magnet while still allowing for individual replacement of each part

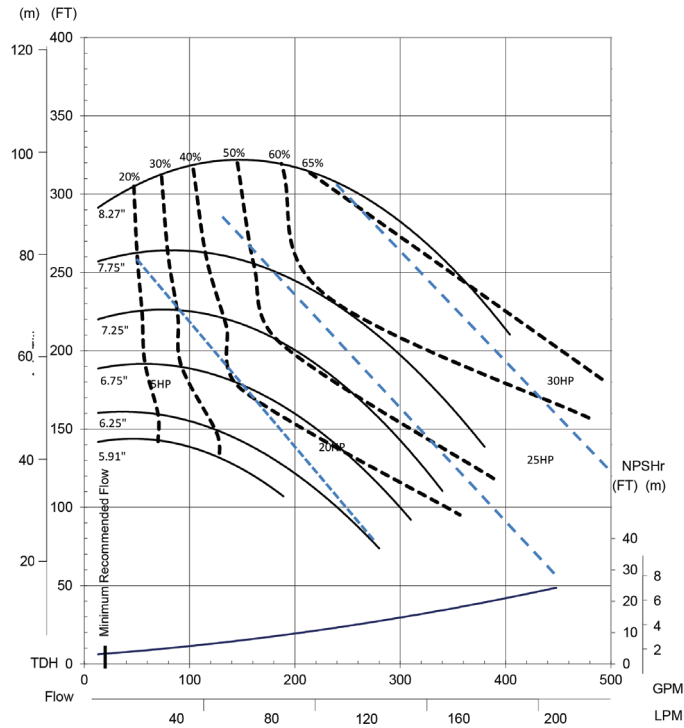
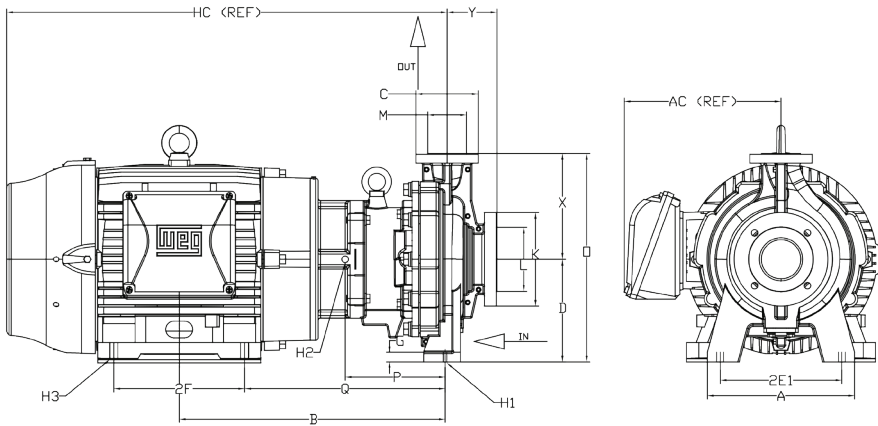
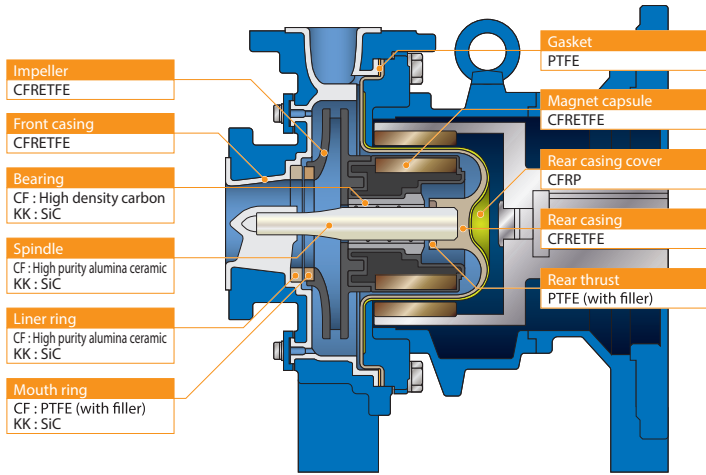

MODEL	PUMP FLANGES		DIMENSIONS (INCHES)			
	SUCTION	DISCHARGE	K	L	C	M
MDM-3158	3"	1.5"	7.52	5.16	5.00	3.11

MIN. FLOW	MAX HEAD	MAX CAPACITY	PUMP WEIGHT
13 GPM	312 FT	400 GPM	185 LBS

PUMP DIMENSIONS (INCHES)																
HP / FRAME	A	AC	B	D	2E1	2F	G	H1	H2	H3	HC	O	P	Q	X	Y
7.5-10 / 213-215TC	11.81	9.21	18.59	8.25	9.76	5.50	0.79	0.28	0.53	0.66	26.82	16.75	9.02	15.09	8.50	4.00
15-20 / 254-256TC	11.81	10.03	17.83	8.25	9.76	82.50	0.79	0.28	0.53	0.66	28.09	16.75	N/A	12.83	8.50	4.00
25-30 / 284-286 TSC	11.81	12.27	21.09	8.25	9.76	9.50	0.79	0.28	0.53	0.66	32.50	16.75	9.02	15.59	8.50	4.00
40-50 / 324/26 TSC	11.81	12.58	21.34	8.25	9.76	10.50	0.79	0.28	0.53	0.66	35.35	16.75	8.03	16.09	8.50	4.00