

## MDM-328 7.5-50 HP

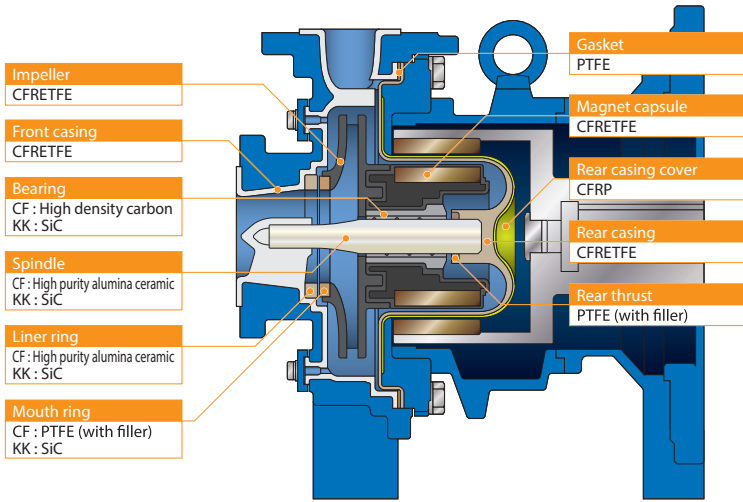

- **Non-contact Bearing System** allows dry run operation (CF models only)
- **Simple, rugged design**
- **Corrosion resistant ETFE internals**
- **Spline/pinned impeller design** provides positive locking of impeller/inner magnet while still allowing for individual replacement of each part

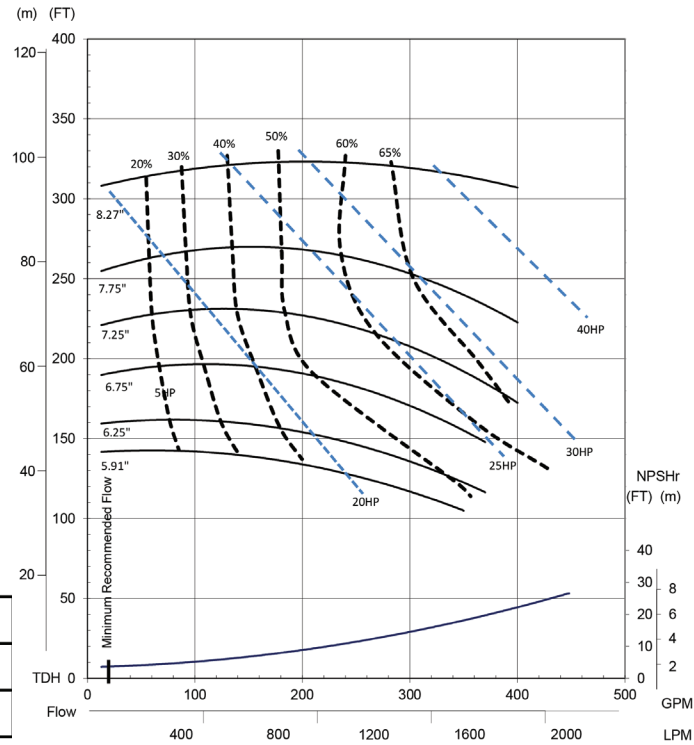
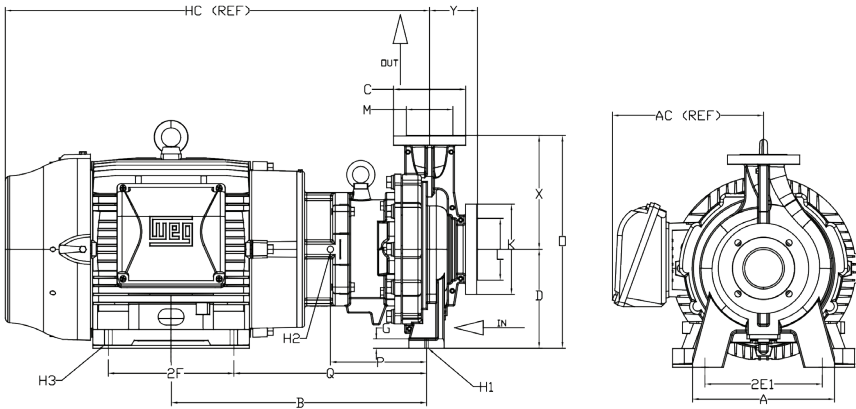

MODEL	PUMP FLANGES		DIMENSIONS (INCHES)			
	SUCTION	DISCHARGE	K	L	C	M
MDM-328	3"	2"	7.52	5.16	6.02	3.90

MIN. FLOW	MAX HEAD	MAX CAPACITY	PUMP WEIGHT
13 GPM	323 FT	400 GPM	190 LBS

HP / FRAME	PUMP DIMENSIONS (INCHES)															
	A	AC	B	D	2E1	2F	G	H1	H2	H3	HC	O	P	Q	X	Y
7.5-10 / 213-215TC	11.81	9.21	18.59	8.25	9.76	5.50	0.79	0.28	0.53	0.66	26.92	17.75	9.02	15.09	9.50	4.00
15-20 / 254-256TC	11.81	10.03	20.59	8.25	9.76	8.25	0.79	0.28	0.53	0.66	30.94	17.75	9.02	15.59	9.50	4.00
25-30 / 284-286 TSC	11.81	12.27	21.09	8.25	9.76	9.50	0.79	0.28	0.53	0.66	32.60	17.75	9.02	15.59	9.50	4.00
40-50 / 324/26 TSC	11.81	12.58	21.34	8.25	9.76	10.50	0.79	0.28	0.53	0.66	35.45	17.75	8.03	16.09	9.50	4.00