

MDM-1518-2 25HP

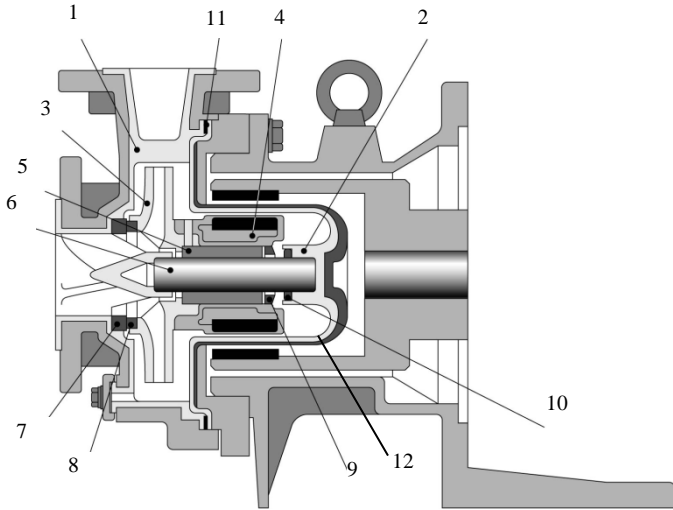

- ❑ Exceeds ANSI performance standards in ANSI dimensional design
- ❑ Simple, rugged, modular design
- ❑ Dual back pull-out
- ❑ Non-contact Bearing System allows dry run operation (CF models only)

Part	Material		
	ECF	EKK	PKK
1 Front casing	CFRETFE (carbon fiber reinforced ETFE)		PFA
2 Containment shell			
3 Impeller			
4 Inner magnet assy			
5 Bearing	High density carbon	SiC	
6 Shaft	High purity alumina ceramic		
7 Front outboard thrust collar	PTFE		
8 Front inboard thrust collar	High purity alumina ceramic		
9 Rear inboard thrust collar	PTFE (filler charged)		PTFE
10 Rear outboard thrust collar			
11 Gasket	PTFE		
12 Support	Kevlar®		

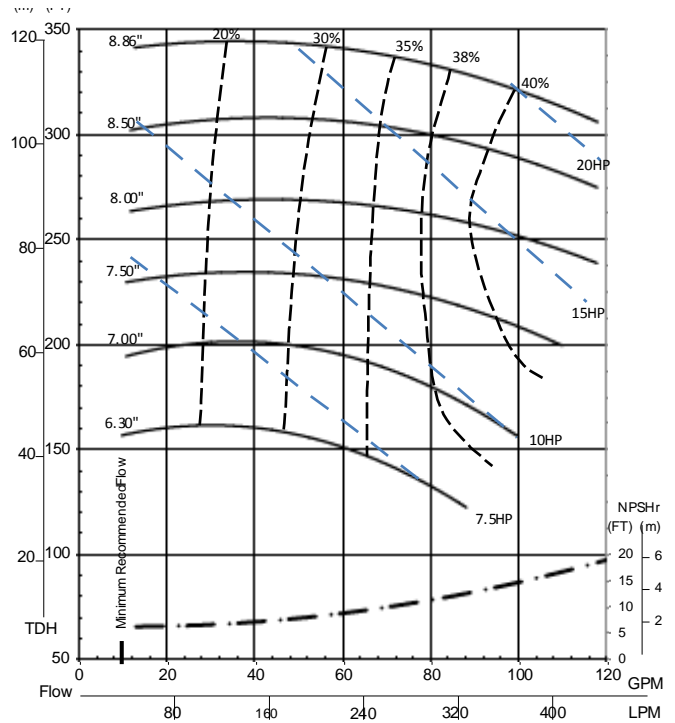

Dimensions (inches) and Specifications

Note: Will vary by motor manufacturer

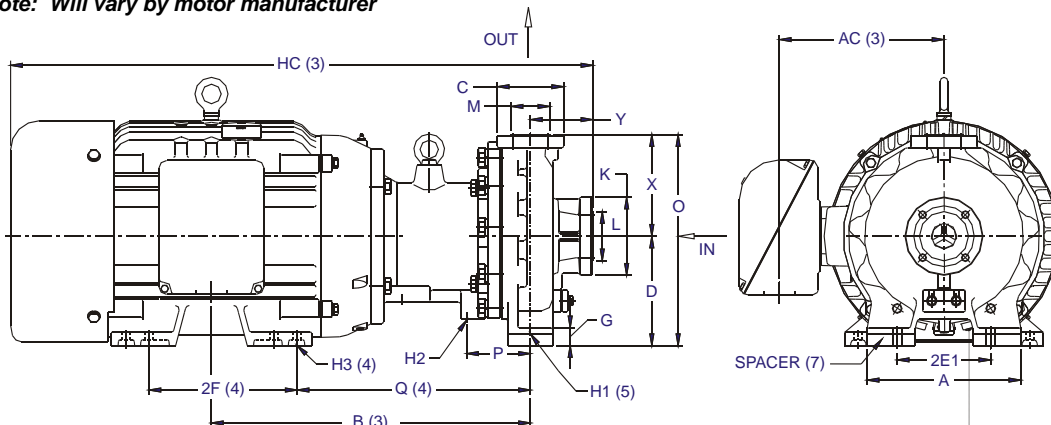

A	AC(3)	B(3)	D	2E1	2F(4)	G	H1(5)	H2	H3(4)	HC(3)	O	P	Q(4)	X	Y	
9.84	10.56	20.47	7.00	6.00	9.50	1.14	0.55	3/8-16 UNC	0.52	37.35	13.50	4.09	14.97	6.50	4.00	
HP/Frame			Connection Sizes		Min Flow/Max Head		Standard Capacity		Max Capacity		Pump Weight*		K	L	C	M
25/284TSC			1.5 x 1		13/348		90		120		154		5.00	3.15	4.25	2.48

*Pump end only. Does not include motor.