

MX

series

Model Identification Code

MX-F 400 CFV 6

Series symbol

MX: GFRPP casing
MX-F: CFRETFE casing

Pump size

Suction x discharge	Motor HP
250: 1" x 1"	0.5 HP
251: 1" x 1"	1.0 HP
400: 1½" x 1½"	0.75 HP
401: 1½" x 1½"	1.5 HP
402: 2" x 1½"	2.0 HP
403: 2" x 1½"	3.0 HP
505: 2½" x 2"	5.0 HP

Material of Bearing/Spindle/O-ring

MX CV: High density carbon/Alumina ceramic/FKM (EPDM/AFLAS®)
RV: PTFE/Alumina ceramic/FKM (EPDM/AFLAS®)
AV: Alumina ceramic/Alumina ceramic/FKM (EPDM/AFLAS®) (models MX-250 to MX-401)

MX-F CFV: High density carbon/High Purity Alumina ceramic/FKM (EPDM/AFLAS®)
RFV: PTFE/High Purity Alumina ceramic/FKM (EPDM/AFLAS®)
KKV: SiC/SiC/FKM (EPDM/AFLAS®)
AFV: Alumina ceramic/Alumina ceramic/FKM (EPDM/AFLAS®) (models MX-F250 to MX-F401)

Impeller mark

MX 5: 50 Hz
6: 60 Hz
7: Large impeller

MX-F X: 50/60 Hz
V: 50/60 Hz

Liquid End Construction

MX-(F)250 to (F)401 and MX-505

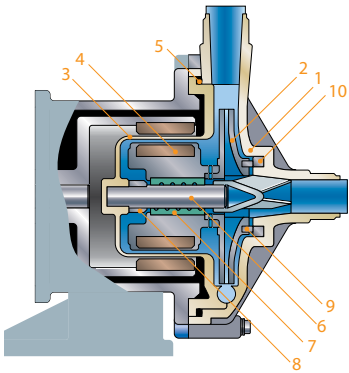

Model	MX-402 to 505		
	MX-250 to 401		
Mark	AV(AE)	CV (CE)	RV (RE)
1 Front casing	GFRPP		
2 Impeller	GFRPP		
3 Rear casing	GFRPP		
4 Magnet capsule	PP		
5 O-ring	FKM ¹		
6 Spindle	High Purity Alumina Ceramic		
7 Bearing	Alumina Ceramic	Carbon	PTFE
8 Rear thrust	CFRPPS	CFRPPS ²	
9 Mouth ring	PTFE		
10 Thrust/Liner ring	Alumina Ceramic		
11 Lock pin	----	GFRPPS (only on 402 -505)	

MX-(F)402(H) & (F)403(H)

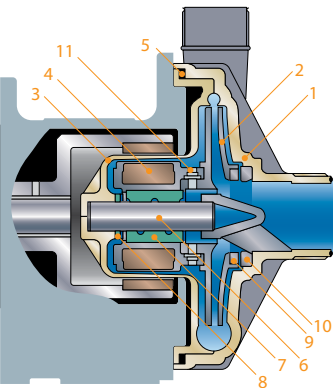

Model	MX-F402 & F403			
	MX-F250 to F401			
Mark	CFV	RFV	KKV	AFV
1 Front casing	CFRETFE			
2 Impeller	CFRETFE			
3 Rear casing	CFRETFE			
4 Magnet capsule	CFRETFE			
5 O-ring	FKM ¹			
6 Spindle	High Purity Alumina Ceramic	SiC	High Purity Alumina Ceramic	
7 Bearing	Carbon	PTFE	SiC	High Purity Alumina Ceramic
8 Rear thrust	CFRETFE		CFRETFE ³	CFRETFE
9 Mouth ring	PTFE		SiC	PTFE
10 Thrust/Liner ring	High Purity Alumina Ceramic		SiC	High Purity Alumina Ceramic
11 Lock pin	CFRETFE (only on F402 & F403)			----

1 EPDM and AFLAS® o-ring also available 2 402-403H have CFRPEEK rear thrust collars 3 F402-403 have CFRPFA rear thrust collars

Performance Curves

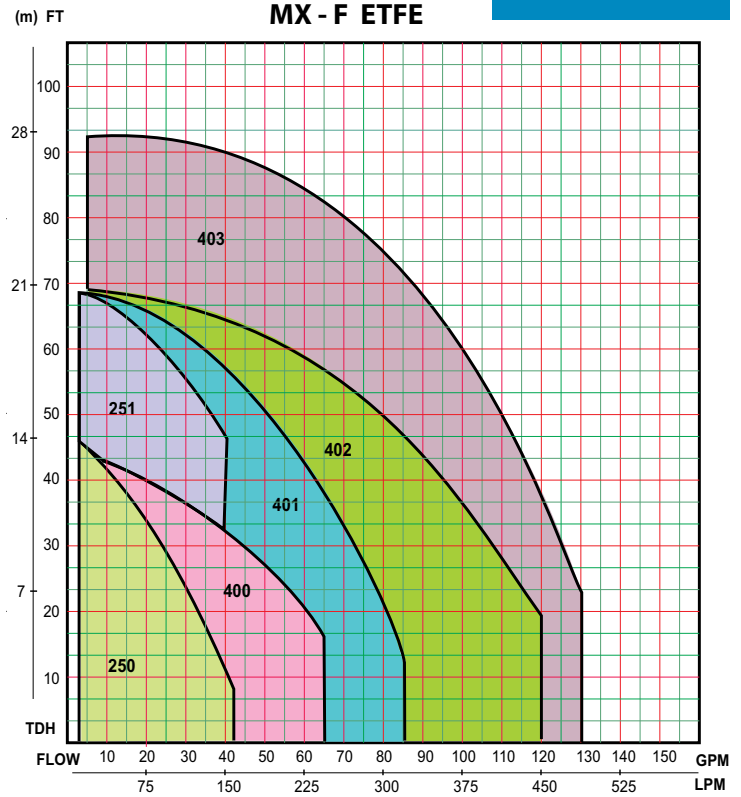
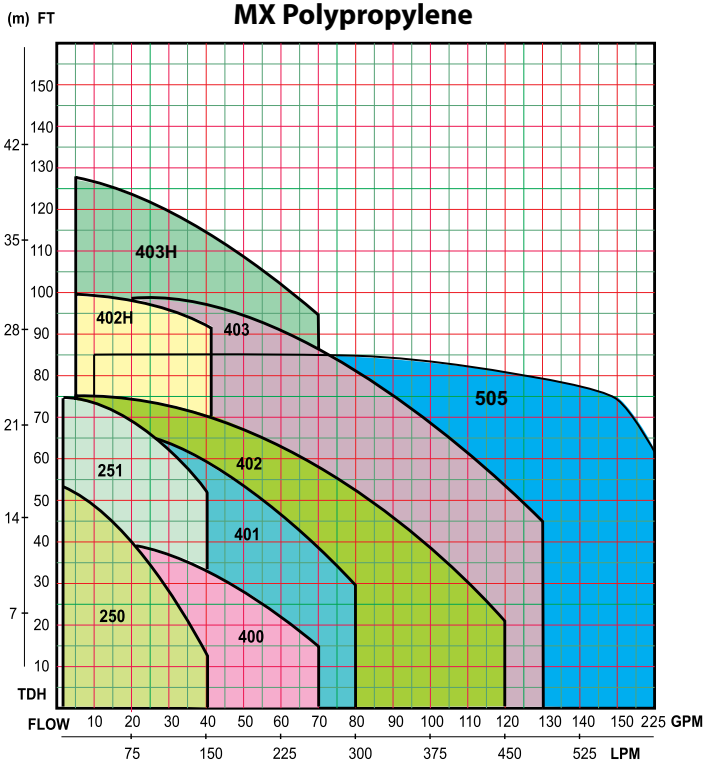

Performance based on water @ 70°F (21°C). Fluids with specific gravity other than 1.0 should be reviewed by the factory.

Specifications

Model	Suction & Discharge (NPT)	Max Discharge Pressure (ft)	Max Flow (GPM)	Specific Gravity	Motor output @ 60 Hz	Weight (less motor) lbs
MX-250	1" x 1"	53	40	1.0	0.5 HP	17.0
MX-251	1" x 1"	75	40	1.0	1 HP	22.5
MX-400	6 1.5" x 1.5"	38	70	1.2	0.75 HP	13.7
	7 1.5" x 1.5"	43	70	1.2	0.75 HP	13.7
MX-401	6 1.5" x 1.5"	59	80	1.2	1.5 HP	22.5
	7 1.5" x 1.5"	68	80	1.2	1.5 HP	22.5
MX-402	2" x 1.5"	73	107	1.2	2 HP	29.8
MX-402H	2" x 1.5"	99	45	1.0	2 HP	29.8
MX-403	2" x 1.5"	101	130	1.2	3 HP	32.0
MX-403H	2" x 1.5"	126	70	1.0	3 HP	32.0
MX-505	2.5" x 2"*	86	225	1.2	5 HP	59.5
MX-F250	1" x 1"	48	43	1.2	0.5 HP	17.0
MX-F251	1" x 1"	69	40	1.0	1 HP	22.5
MX-F400	V 1.5" x 1.5"	43	65	1.2	0.75 HP	13.7
	X 1.5" x 1.5"	34	65	1.2	0.75 HP	13.7
MX-F401	V 1.5" x 1.5"	68	86	1.2	1.5 HP	22.5
	X 1.5" x 1.5"	50	75	1.2	1.5 HP	22.5
MX-F402	2" x 1.5"	70	120	1.2	2 HP	29.8
MX-F403	2" x 1.5"	93	130	1.2	3 HP	32.0

* Flanged connections only

Dimensions

■ MX-F250 to F401

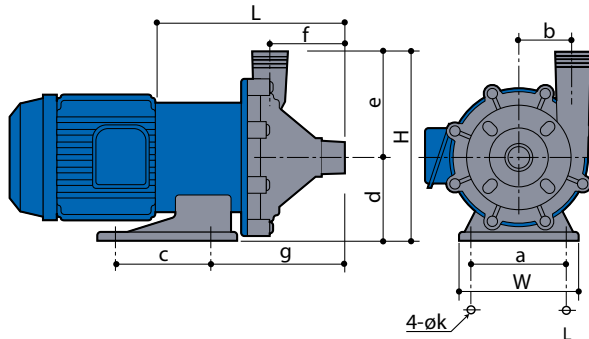

■ MX-F402, F403

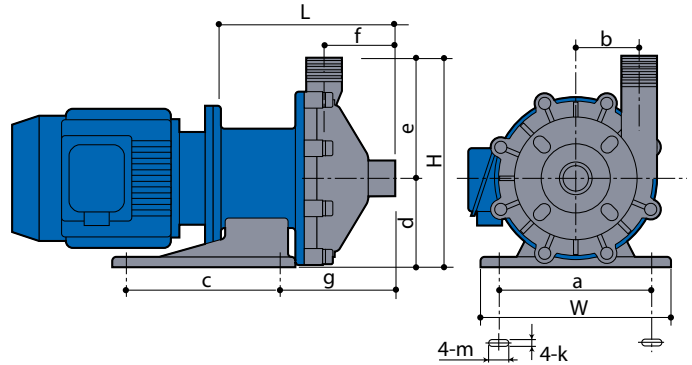

■ MX-505

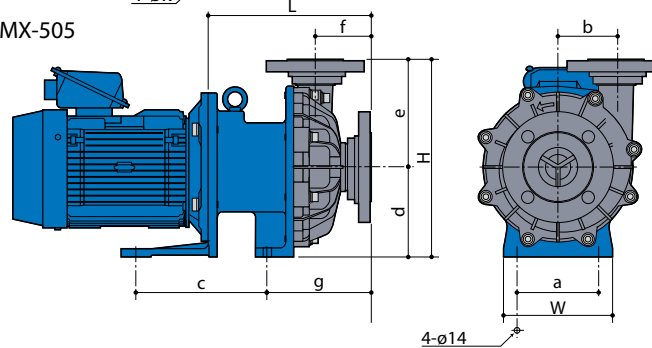

Inches (mm)

Model	W	H	L	a	b	c	d	e	f	g	k	m
MX-(F)250	6.30 (160)	9.75 (248)	9.39 (239)	5.12 (130)	2.56 (65)	5.12 (130)	4.53 (115)	5.22 (133)	3.25 (83)	6.12 (155)	0.47 (12)	---
MX-(F)251	6.30 (160)	9.75 (248)	9.39 (239)	5.12 (130)	2.56 (65)	5.12 (130)	4.53 (115)	5.22 (133)	3.25 (83)	6.12 (155)	0.47 (12)	---
MX-(F)400	5.51 (140)	8.62 (219)	9.37 (238)	4.33 (110)	2.13 (54)	3.86 (98)	3.74 (95)	4.88 (124)	3.19 (81)	5.67 (144)	0.47 (12)	---
MX-(F)401	6.30 (160)	9.81 (249)	9.96 (253)	5.12 (130)	2.83 (72)	5.12 (130)	4.53 (115)	5.28 (134)	3.82 (97)	7.01 (178)	0.47 (12)	---
MX-(F)402/403 (H)	10.24 (260)	10.78 (274)	9.53 (242)	8.19 (208)	3.15 (80)	7.87 (200)	4.72 (120)	6.06 (154)	3.27 (83)	5.94 (151)	0.55 (14)	1.42 (36)
MX-505	7.09 (180)	12.99 (330)	11.32 (288)	5.51 (140)	3.78 (96)	8.66 (200)	5.91 (150)	7.09 (180)	3.74 (95)	6.89 (175)	0.47 (12)	---

Patented Split Volute Casing

The MX Series is the first resin magnet pump that uses a split volute pump casing that forms a vortex chamber. The volute limits the liquid flow from the impeller and returns it to the pump, which is efficiently guided to the discharge port to enhance overall efficiency.

Patented Self-radiating structure

Through heat dispersion holes provided in fixed portions of the impeller and the magnet capsule, the liquid around the spindle and bearing is forced to circulate. Heat generated by friction can be reduced effectively, thereby preventing any thermal deformation and reducing wear.

MX utilizes standard NEMA frame motors making them easy to install. (IEC and JIS versions available)

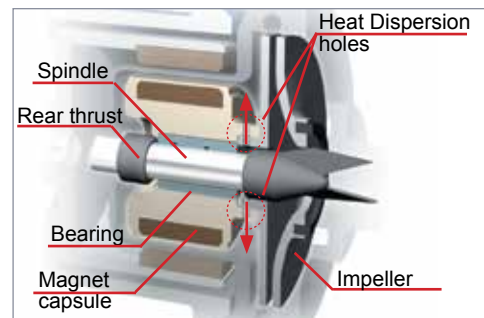

Front casing

Rear casing

Reinforced front casing



IALT00035.K March 2015

www.IwakiAmerica.com

Five Boynton Road • Holliston, MA • 01746 USA • Tel: 508-429-1440 • info@iwakiAmerica.com