

IWAKI

Magnetic Drive Turbine Pump

MDT Series

Instruction Manual

 Read this manual before use of product

Thank you for having selected IWAKI's magnetic drive turbine pump MDT Series. This instruction manual deals with the correct handling and operation of the pump. You are requested to read this manual prior to installing and using the pump to ensure safe and long life of the pump. The content of this manual may be changed without notice.



Contents

| | |
|--|---------|
| Safety Instructions | 1, 2 |
| Outline of Product | |
| 1. Unpacking and inspection | 3 |
| 2. Operating principle | 3 |
| 3. Model identification | 4 |
| 4. Specification | 4 |
| 5. Dimension | 5 |
| 6. Main parts and label | 6 |
| 7. Performance curves | 6 ~ 8 |
| Installation | |
| 1. Before use of product | 9 |
| 2. Precautions on operation | 9, 10 |
| 3. Installation, plumbing and wiring | 11 ~ 13 |
| Operation | |
| 1. Operation | 14 |
| Maintenance | |
| 1. Troubleshooting | 15 |
| 2. Maintenance and inspection | 16 |
| 3. Wear parts | 16 |
| 4. Disassembly and assembly | 17 ~ 20 |
| 5. Construction and parts names | 21 |

Important Instruction

For the Safe and Correct Handling of the Pump

- Read the “Safety Instructions” sections carefully to prevent accidents involving your customers or other personnel and to avoid damage or loss of other assets. Always follow the instructions and advice found in these sections.
- Observe and abide by the instructions described in this manual. These instructions are very important for protecting pump users from dangerous conditions and situations related with the use of the pump system.
- The symbols relate to the following meanings described below:

| | |
|--|---|
|  Warning | Nonobservance or misapplication of the contents of the “Warning” section could lead to a serious accident, including death or injury. |
|  Caution | Nonobservance or misapplication of the contents of the “Caution” section could lead to serious physical injury to the user or serious damage to the product. |

Types of Symbols



Indicates that “Warning” or “Caution” must be exercised. Inside this triangle, a concrete and practical image provided as a warning or caution message is depicted.



Indicates a prohibited action or procedure. Inside or near this circle, a concrete and practical image of the activity to be avoided is depicted.



Indicates an important action or procedure which must be performed or carried out without fail. Failure to follow the instructions herein can lead to malfunction or damage to the pump.

Safety Instruction

Warning

- **Turn off the power supply.**

Working without disconnecting the power supply may cause an electrical shock. Before engaging upon any working procedures involving the pump, make sure to turn the power supply switch off and to stop the pump and other related devices.



- **Stop works.**

When you detect or become aware of a dangerous sign or abnormal condition when you work on pump, stop works immediately and start it from the beginning again.



- **For specified application only.**

The use of a pump in an application other than those clearly specified may result in injury or damage to the pump. Use the pump strictly in accordance with the pump specifications and application range.



Prohibited

- **No remodeling.**

Never remodel a pump. Otherwise, a serious accident may result. Iwaki will not be responsible for any accident or damage of any kind which is caused by the user remodeling the pump without first obtaining permission or instructions from Iwaki.



No Remodeling

- **Wear protectors.**

If you touch or come in contact with any type of hazardous chemical liquid, you may be harmed. Wear protective gear (protective mask, gloves, etc.) during the works for the pump.



Wear protective gear

Caution

- **Qualified operators only.**

The pump operator and pump operation supervisor must not allow any operators who have little or no knowledge of the pump to run or operate the pump. Pump operators must have enough knowledge of the pump and its operation.



Prohibited

- **Specified power only.**

Do not operate the pump on voltage which is not specified on the nameplate. Failure to do so may result in damage or fire. Only the specified power level is to be applied.



Prohibited

- **Do not wet or dampen.**

If the motor or wiring cable becomes wet or dampened with the operating liquid by mistake, this may result in a fire or cause an electrical shock. Install the motor and wiring cable in positions which are not likely to become wet or dampened with any liquid.



Prohibited

- **Ventilate.**

Poisoning may result during an operation which involves toxic or odorous liquid. Ventilate the operating site sufficiently.



Caution

- **Spill-out accident.**

Protective measures should be taken against any accidental spill-out or leakage of the operating liquid as a result of unexpected damage on the pump or the related piping.



Caution

- **Operating site must be free of water and humidity.**

The pump is not designed to be water-proof or dust-proof. The use of the pump in places where water splashes or humidity is high may result in an electrical shock or short circuit.



Prohibited

Safety Instruction

Caution

- **Do not damage power cable.**

Do not scratch, damage, process, or pull the power cable forcibly. An extra load onto the cable, such as heating the cable or placing something heavy on the cable, may damage the cable and finally cause a fire or an electrical shock.



Caution

- **Do not cover the motor.**

Running a covered motor may accumulate heat inside the motor and cause a fire or a mechanical failure. Ventilate the motor sufficiently.



- **Arrange grounding.**

Do not operate the pump without connecting the grounding wire. Otherwise, an electrical shock may result. Make sure the grounding wire is connected with the grounding terminal.



Grounding

- **Install an earth leakage breaker.**

The operation of a pump without using an earth leakage breaker may cause an electrical shock. Please install a leakage breaker.



Electrical Shock

- **Power cable cannot be replaced.**

Never use a damaged or affected power cable. Otherwise, a fire or an electrical shock may result. Handle the power cable carefully, as it cannot be replaced by a new cable. (The complete motor must be replaced in that circumstance.)



Caution

- **Do not use damaged pump.**

Use of damaged pump may cause short-circuit and electrical shock. Never use damaged pump.



Prohibited

Caution

- **Limited operating site and storage.**

Do not install or store the pump in the following places:

- * Places where a flammable gas or material is used or stored.
- * Places where the ambient temperature is extremely high (40°C or higher) or extremely low (0°C or lower).



Prohibited

- **Do not drain the liquid in the site.**

The liquid discharged out of the pump, including a hazardous chemical liquid, must be drained into a special container. Never drain such liquid directly onto the floor in or near the operation site.



Prohibited

- **Disposal of used pump.**

Disposal of used or damaged pumps must be done in accordance with the relevant local laws and regulations. (Consult a licensed industrial waste products disposing company.)



- **Replacement of parts.**

Replacement of parts must be done according to this instruction manual. Do not disassemble pump exceeding the extent shown on this manual.



- **Countermeasure for static electricity.**

When liquids with a conductivity at rest of less than 1000 pS/m, especially less than 100 pS/m (e.g. hydrocarbons and halogenated hydrocarbons) are pumped, static electricity may be produced inside the pump during high flow velocities, which causes leakage from pump housing due to pin holing. Take countermeasure to avoid static electricity (e.g. increase conductivity, reduce flow velocity). Dangerous static electricity is not expected to occur with homogenous water mixed liquids.



Outline of Product

1. Unpacking and inspection

After unpacking the product, check to see:

- 1) If model name, discharge capacity, discharge pressure, voltage etc. shown on the nameplate are those that you order.
- 2) If the product is not damaged or its bolts and nuts are not loosened during transportation.

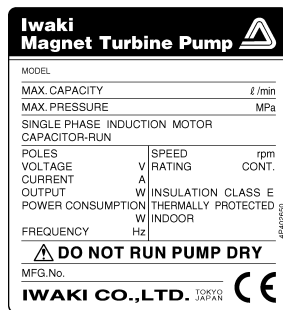

If you find any abnormality, please contact your dealer.

2. Operating principle

The impeller (turbine) is rotated by magnetic coupling. The rotating impeller makes vortex flow towards rotating direction to transfer liquid from suction port to discharge port making high discharge pressure.

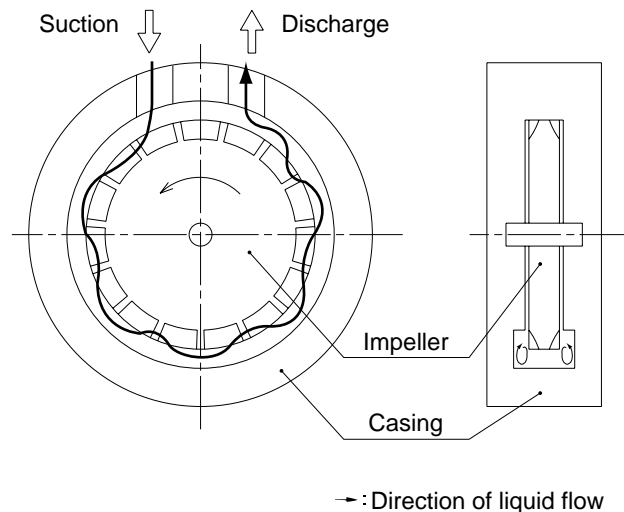

Outline of Product

3. Model identification

MDT - 20 L C A 220
 (1) (2) (3) (4) (5) (6)

- (1) Series code
- (2) Max. discharge flow (50/60Hz)
 15 : 14/16
 20 : 17/20
- (3) Liquid temperature
 L : 65 deg. C or below
 H : 95 deg. C or below
- (4) Bearing material
 C : Carbon
 D : Siliconized graphite
- (5) Size of connection bore
 A : R1/2
 B : 1/2NPT
- (6) Power source voltage
 100 : AC100V (Single phase)
 115 : AC115V (Single phase)
 200 : AC200V (Three phase)
 220 : AC220~240V (Single phase)

4. Specification

50/60Hz

| Model | Max. flow L/min. | Max. press. MPa | Max. vacuum kPa (Abs.) | Rated rpm | Motor | | Mass kg |
|---------------|---------------------|--------------------|---------------------------|--------------|-------------|----------|------------|
| | | | | | Voltage | Amperage | |
| MDT-15L()100 | 14/16 | 0.35 | 8.00 | 2800/3280 | AC100 | 3.6/3.9 | 6.3 |
| MDT-15L()115 | | | | | AC115 | -/3.2 | |
| MDT-15L()200 | | | | | AC200 (3ph) | 1.2/1.3 | |
| MDT-15L()220 | 14/16 | 0.35 | 9.33 | 2760/3140 | AC220~240 | 1.4/1.7 | 6.7 |
| MDT-15H()100 | | | | | AC100 | 3.6/3.9 | 6.3 |
| MDT-15H()115 | | | | | AC115 | -/3.2 | |
| MDT-15H()200 | AC200 (3ph) | 1.2/1.3 | | | | | |
| MDT-15H()220 | 17/20 | 0.35 | 8.00 | 2800/3280 | AC220~240 | 1.4/1.7 | 6.7 |
| MDT-20L()100 | | | | | AC100 | 3.6/3.9 | 6.3 |
| MDT-20L()115 | | | | | AC115 | -/3.2 | |
| MDT-20L()200 | AC200 (3ph) | 1.2/1.3 | | | | | |
| MDT-20L()220 | 17/20 | 0.35 | 8.00 | 2760/3140 | AC220~240 | 1.4/1.7 | 6.7 |
| MDT-20H()100 | | | | | AC100 | 3.6/3.9 | 6.3 |
| MDT-20H()115 | | | | | AC115 | -/3.2 | |
| MDT-20H()200 | AC200 (3ph) | 1.2/1.3 | | | | | |
| MDT-20H()220 | 17/20 | 0.35 | 8.00 | 2760/3140 | AC220~240 | 1.4/1.7 | 6.7 |

- Note 1. Above mentioned performance is based on pumping clear water at temperature of 25 deg. C. Flow rate changes depending on the temperature of liquid. Ask us for details.
2. Ask us for other liquid than water.
3. Allowable ambient temperature is 0 ~ 40 deg. C.

Outline of Product

5. Dimension

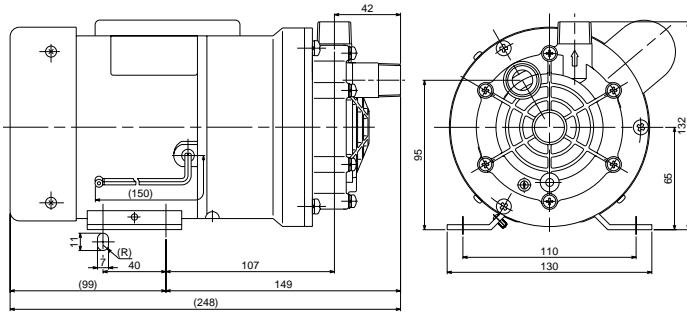

MDT-15/20-100V

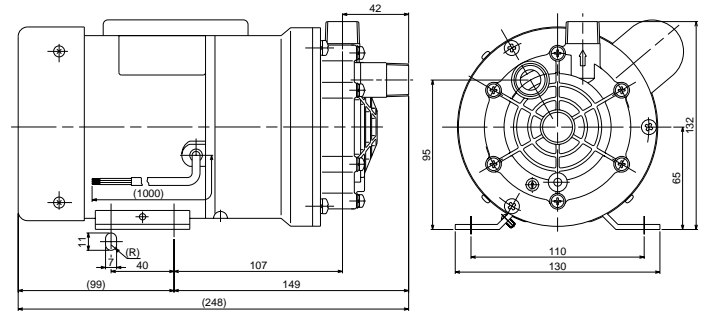

MDT-15/20-115V

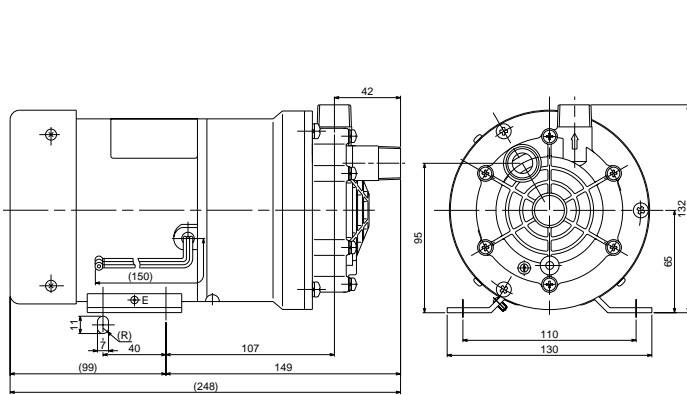

MDT-15/20-200V (3ph)

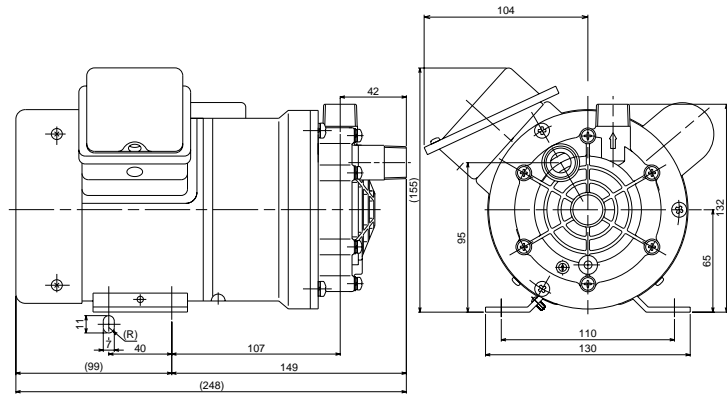

MDT-15/20-220V

Outline of Product

6. Main parts and label

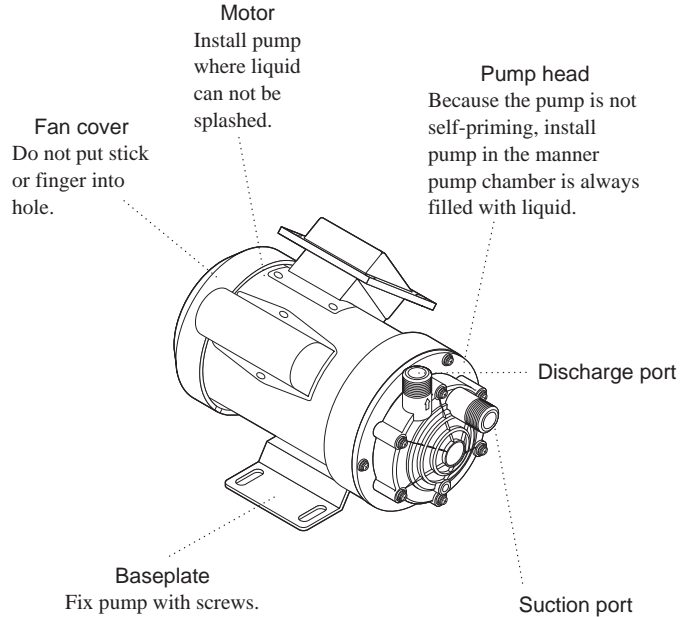

7. Performance curves

MDT-15L

Water at 25 deg. C

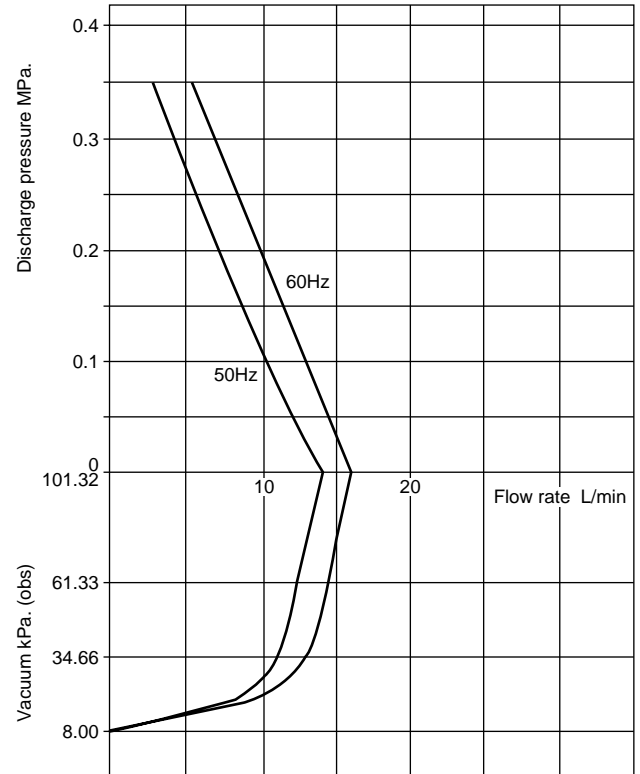

Outline of Product

MDT-15H

Water at 25 deg. C

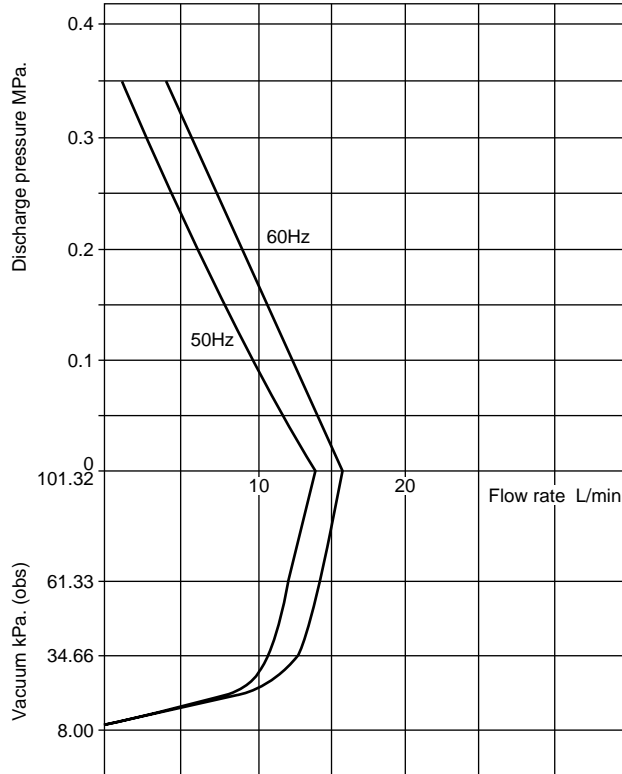

MDT-20L

Water at 25 deg. C

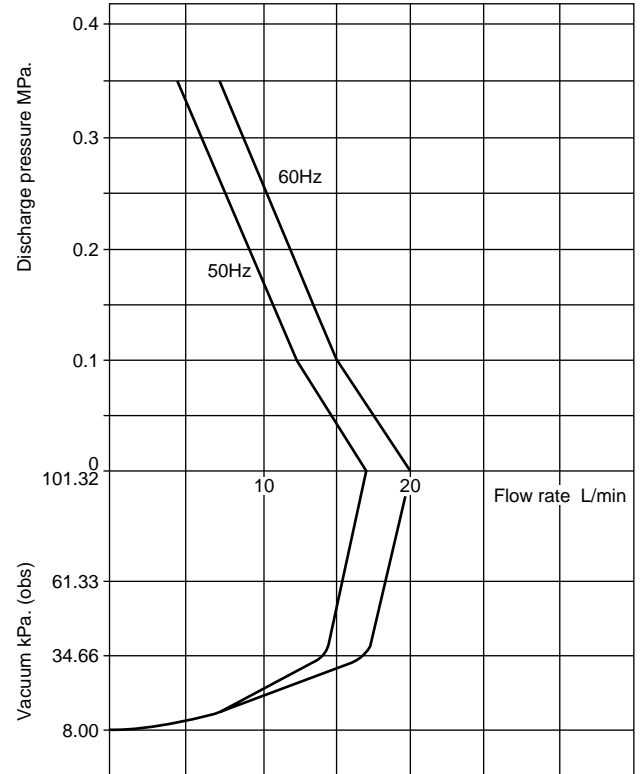

Outline of Product

MDT-20H

Water at 25 deg. C

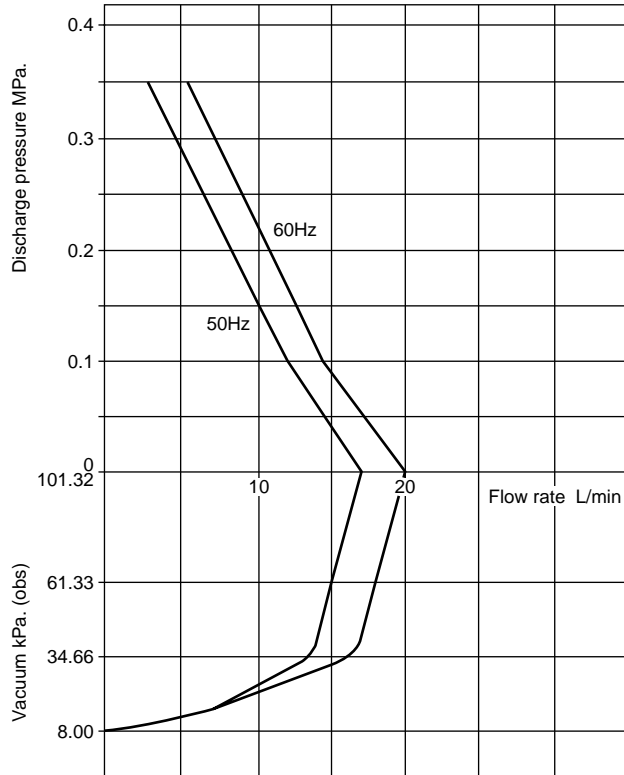

Installation

1. Before use of product



Do not run pump dry

Dry running of pump causes quick wearing of impeller and bearing.

Do not close discharge and suction valves

If pump is operated with suction and discharge valves closed, temperature inside pump excessively increases in a short time resulting in pump failure or burning. Operate pump with valves opened.

Do not install pump outdoor

Motor is not water-proof construction. If liquid is splashed on motor, it may cause fire or damage of motor. Do not install pump outdoor.

Keep fire away from pump

Do not put dangerous or flammable substance around pump.

Damaged pump

Do not use damaged pump to avoid short-circuit or electrical shock.

2. Precautions on operation

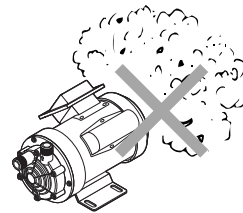
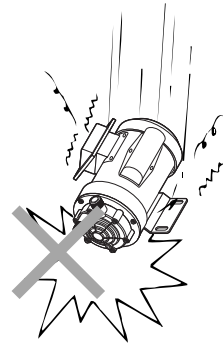

- (1) **Handle pump carefully**
Strong impacts on pump caused by dropping it on floor or so may result in damage or faulty performance of pump.
- (2) **Do not touch pump**
Pump/motor is very hot during operation or just after it is stopped. Do not touch it with bare hand.
- (3) **Prime pump**
Pump is not self-priming. Prime pump with liquid before starting pump.
- (4) **Keep pump away from dusty atmosphere**
Do not use pump at dusty atmosphere and take measures for dust not to adhere to motor.

Installation

(5) Install earth leakage breaker

Install earth leakage breaker to avoid accident such as electrical shock etc.

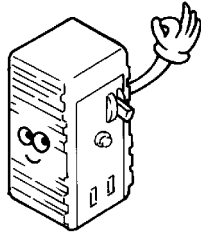

(6) Do not splash liquid on motor.

If motor or wires are wetted by splashed liquid, it may cause fire or electrical shock. Install pump at place where liquid can not be splashed on pump/motor.

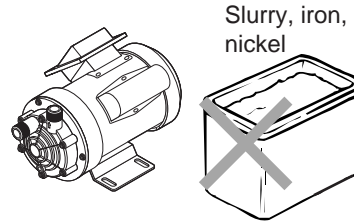
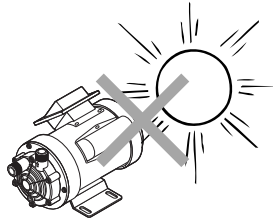

(7) Place to be installed

Do not install or store pump at following places.

- where exposed to direct sunlight
- where ambient temperature increases to 40 deg. C or more
- where humid and dusty atmosphere
- where ambient temperature becomes 0 deg. C or below.
- where exposed to rain and wind
- Change of liquid temperature
The change of pumped liquid temperature at pump starting, during operation and at stopping must be limited to 80 deg. C. or less.

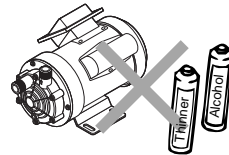

(8) Ground

Connect ground from ground wire.

(9) Prohibited liquids

Following liquids can not be pumped.

- liquids which contain iron or nickel powder
- liquids which contain slurry
- liquids which are crystallized when stopping
- flammable liquids such as gasoline or kerosene
- Viscous liquid
- Liquid of which vapor pressure is 0.6MPa or more.

(10) Power cord can not be replaced.

Do not use pump of which the power cord is damaged.

(11) Maintenance and cleaning

Do not use solvents such as benzene, alcohol or thinner to clean pump. Otherwise, paint gets discolored or peeled.

Installation

3. Installation, plumbing and wiring

3-1. Installation

- 1) Place to be installed
Install the pump at the place where ambient temperature is 40 deg. C or below, relative humidity is 85% or below and where the maintenance and inspection works can be done easily. Do not install pump outdoor.
- 2) Install the pump the lower position than liquid level of suction tank (Flooded suction piping).
- 3) Fix baseplate
Fix the baseplate with screws M6. If the noise is large because of resonance of mounting floor, mount the pump via rubber cushion. Mount the pump in horizontal position.

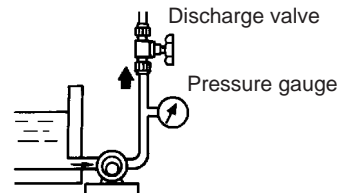
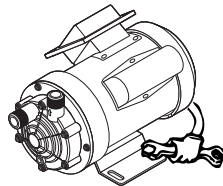
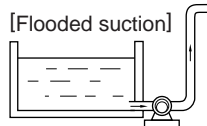

3-2. Plumbing

- 1) To minimize the pipe resistance of liquid, use the piping as short and as less bends as possible.
- 2) Connect joints to the suction and discharge ports of pump. Apply seal tape so that the air can not be sucked in. Above all improper connection of suction side joint will cause air being sucked resulting in fallen pump performance. Refer to "Model identification" on page 4.
- 3) When you screw the joints in suction and discharge ports, hold the pump head with hand but do not hold the motor. Tightening torque is 6N·m or less.
- 4) A pressure gauge installed at discharge piping enables you to find the abnormal operation of pump.

Installation

- 5) For hose piping, use correct size of hose to ensure firm connection.

Use the hose of which the material can chemically resist to the pumped liquid.

Use the hose such as Teflon hose which can endure the pressure made by the pump.

 **Caution**

Suction side hose may be collapsed due to vacuum made by pump operation. When hose is used, employ the durable one such as blade hose. Special attention must be paid when pumping high temperature liquid.

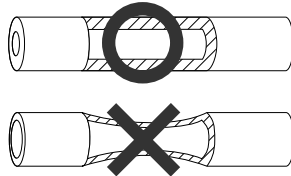

- 6) Periodically check the piping if it is not loosened and tighten it if loosened.

Installation

3-3. Wiring



Caution

Electrical and wiring works must be done by qualified electrician. Otherwise accident of injury or damage may happen.

- 1) Before wiring is done, check if the main power source is switched off.
- 2) Use the power of pump which is indicated on the nameplate of pump.
- 3) The pump has no ON/OFF switch. The pump starts running as soon as the power cord is connected to the power source.
- 4) Take the ground.
- 5) In case the earth leakage breaker is installed and when it is operated, reset it after the reason is settled. Switch off the power when you check the reason.

■ Rated current, starting current

●AC100V

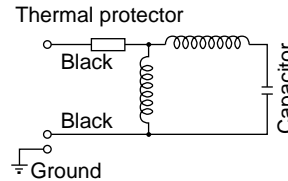

●AC115V

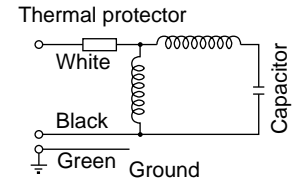

●AC200V (3ph)

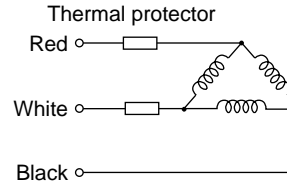

●AC220~240V(Terminal block connection)

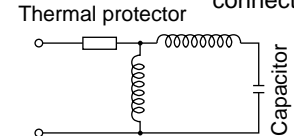

50/60Hz

| Model | Voltage (V) | Rated current (A) | Starting current (A) |
|-------------------|---------------------|-------------------|----------------------|
| MDT-15/20 () 100 | AC100 (1-phase) | 3.6/3.9 | 9.2/8.2 |
| MDT-15/20 () 115 | AC115 (1-phase) | -/3.2 | -/6.3 |
| MDT-15/20 () 200 | AC200 (3-phase) | 1.2/1.3 | 3.9/3.6 |
| MDT-15/20 () 220 | AC220~240 (1-phase) | 1.4/1.7 | 3.15/3.42~2.95/3.15 |

Operation

1. Operation

Operate the pump according to following procedure.



Caution

Do not run pump dry (without liquid) nor run pump with suction and/or discharge valve closed. Otherwise, pump is damaged. Release air from pump chamber. Otherwise pump may be damaged.

| No. | Procedure | Description |
|-----|--|--|
| 1 | Check piping, wiring and power voltage. | <ul style="list-style-type: none">• Check plumbing, wiring according to items “Plumbing” and “Wiring” in Installation section.• Check power voltage according to description on nameplate. |
| 2 | Open valves | <ul style="list-style-type: none">• Fully open the valves on suction and discharge pipings. |
| 3 | Check if liquid is filled in pump chamber. | <ul style="list-style-type: none">• In case of suction lift application, prime liquid sufficiently. |
| 4 | Switch on power to start | <ul style="list-style-type: none">• After above procedures, switch on power and check if pump runs normally. If pump does not discharge liquid, stop it immediately and eliminate the cause referring to item “Troubleshooting”. |
| 5 | Operation | <ul style="list-style-type: none">• Adjust valves gradually to get required flow rate, pressure or vacuum.• Quick opening and closing of valves will cause disconnection of magnetic coupling. If this happened, switch off power to stop motor. Magnetic coupling will recover once the motor stops its rotation.• Do not operate pump with discharge and suction side valves fully or almost fully closed. |
| 6 | Precaution during pump operation | <ul style="list-style-type: none">• Do not get foreign matters into pump. Foreign matter in pump will cause locked impeller or abnormal wear of impeller.• If earth leakage breaker operates, reset it after the cause is eliminated. Switch off the power and check the reason referring to item “Troubleshooting”. |

Maintenance

1. Troubleshooting

| Trouble | Cause | Countermeasures |
|--|--|---|
| Motor stops during operation. | <ul style="list-style-type: none"> • Wrong wiring • Thermal protector operates due to over loaded motor. • Earth leakage breaker operates due to short circuit. | <ul style="list-style-type: none"> • Check and correct wiring. • Reduce viscosity of liquid or discharge pressure. • Check and repair or replace. |
| Pump does not discharge liquid or capacity is low. | <ul style="list-style-type: none"> • No liquid at suction side and pump runs dry. • Air is sucked in from suction side. • Suction side hose is collapsed. • Pressure at suction port is below saturated vapor pressure of pumped liquid. • Viscosity of liquid is too high. • Valve is closed. • Too large pipe resistance • Worn impeller | <ul style="list-style-type: none"> • Fill liquid in suction tank or open suction side valve. • Check suction side piping and correct it. • Replace hose by stronger one. • Decrease liquid temperature or pipe resistance of suction piping. • Decrease liquid viscosity. • Open valve. • Correct piping. • Replace impeller. |
| Magnet coupling is disconnected. | <ul style="list-style-type: none"> • No liquid at suction side and pump runs dry. • Impeller is locked by their swelling. • Impeller is locked by expansion by heat. • Foreign matters adhere to impeller. • Damaged impeller • Magnet capsule touches rear casing. • Valve is fully closed. • Too large pipe resistance. • Wrong pump is used in view of chemical resistibility. | <ul style="list-style-type: none"> • Fill liquid in suction tank or open suction side valve. • Check chemical resistibility of impeller. • Bring down liquid temperature. • Disassemble pump and remove foreign matters. • Replace impeller. • Disassemble pump and repair or replace parts. • Open valve. • Correct piping. • Select suitable pump. |

| Trouble | Cause | Countermeasures |
|-----------------------------|---|---|
| Motor does not start. | <ul style="list-style-type: none"> • Power is not switched on. • Wrong or disconnected wiring. • Failed motor or its winding is disconnected. • Earth leakage breaker operates due to short circuit. • Earth leakage breaker operates due to lack of power capacity. | <ul style="list-style-type: none"> • Switch on power. • Check and correct wiring. • Repair or replace motor. • Check and repair or replace. • Employ larger power capacity. |
| Abnormal noise or vibration | <ul style="list-style-type: none"> • No liquid at suction side and pump runs dry. • Foreign matters on impeller. • Damaged impeller. • Magnet capsule touches rear casing. • Worn impeller. | <ul style="list-style-type: none"> • Fill liquid or open valve of suction side. • Disassemble pump and remove foreign matters. • Replace impeller. • Disassemble pump and repair or replace parts. • Replace impeller. |
| Liquid leaks. | <ul style="list-style-type: none"> • Damaged O ring. • Loosened bolts. • Wrong pump is selected in view of chemical resistibility. | <ul style="list-style-type: none"> • Replace O ring. • Tighten bolts. • Use suitable pump. |

Maintenance







2. Maintenance and inspection

| No. | Check item | Description | Method |
|-----|--|---|--|
| 1 | If pump discharge liquid normally. | <ul style="list-style-type: none"> If liquid is normally transferred. If suction and discharge pressure is normal. | <ul style="list-style-type: none"> Flow meter or by eye. Refer to figures shown on name plate. |
| 2 | If sound and vibration are normal. | <ul style="list-style-type: none"> Abnormal sound or vibration may be generated when pump does not operate normally. Resonance of base to which pump is mounted may enlarge vibration. In this case, take countermeasure such as rubber cushion etc. | <ul style="list-style-type: none"> By eye and year. By eye and year. |
| 3 | If liquid does not leaks or air does not sucked from pump or piping. | <ul style="list-style-type: none"> Tighten bolts of the parts from which liquid leaks. When you see bubbles in discharged liquid, air is sucked in. Check piping and tighten relating bolts. | <ul style="list-style-type: none"> By eye. |
| 4 | If pump or motor surface is not extremely hot. | <ul style="list-style-type: none"> Surface temperature of pump body is same as that of pumped liquid. Surface temperature of motor is within ambient temperature plus approx. 40 deg. C. You may not touch motor but it is not abnormal if it is within this temperature. | <ul style="list-style-type: none"> By touching or thermometer. |

3. Wear parts

To ensure long time pump operation, it is needed to replace the wear parts.

Replace the wear parts listed as below by new ones at the life time (actual running time) shown as below.

| No. | Wear parts | | Q'ty/pump | Life time |
|------|---------------------------|---|-----------|------------|
| 4+5 | Rear casing with bearing |  | 1 | 8,000 hrs. |
| 6 | Magnet capsule |  | 1 | |
| 9 | Rear plate |  | 1 | |
| 10 | Impeller |  | 1 | |
| 4+12 | Front casing with bearing |  | 1 | |
| 7 | O ring |  | 1 | |

Note 1. Above mentioned life time is based on pumping clear water at ambient temperature and the life time is influenced by the pumped liquid, its temperature and other conditions.

2. O ring must be replaced by new one every time when pump is disassembled regardless of above mentioned life time.

Maintenance

4. Disassembly and assembly



Caution

Disassembling and assembling of pump must be done according to this manual. Do not disassemble the pump beyond the extent shown on this manual. We are not responsible for person injury or damage which is caused by non observance of this manual.

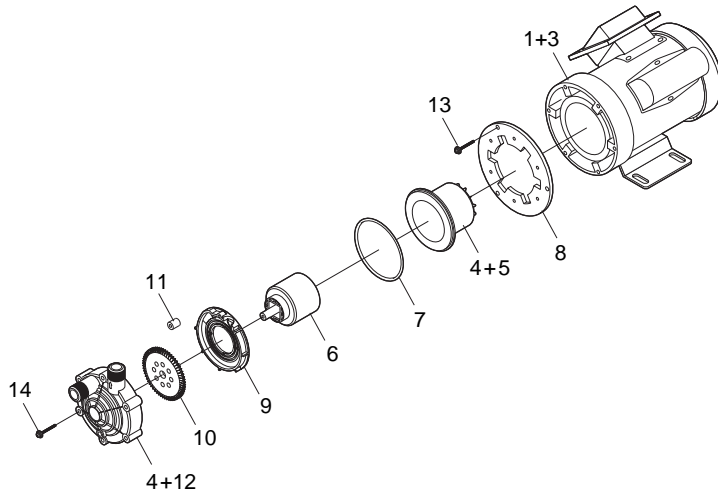

4-1. Disassembly

- 1) Remove three screws (13) to remove pump body + mounting plate (8) from motor (1).
- 2) Remove six screws (14) together with plate washers and spring washers to remove mounting plate (8) from pump body.
- 3) Remove rear casing (5) from front casing (12). As shown on illustration below, turn rear casing by force to remove it. (Strength is needed to turn it.) Pay attention not to drop magnet capsule (6). Also pay attention to the liquid which may stay in rear casing.

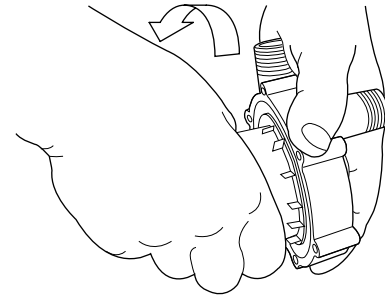

- 4) Remove O ring (7) from rear casing and take out magnet capsule (6).
- 5) Remove rear plate (9) and impeller (10) from front casing (12). Pay attention not to lose positioning pin (11).

Maintenance

4-2. Assembly

1) Put positioning pin (11) on front casing (12) and put impeller (10) on front casing (12) with its boss facing to this side as shown on illustration below.

Coincide center hole of impeller with inner diameter of bearing of front casing (12).

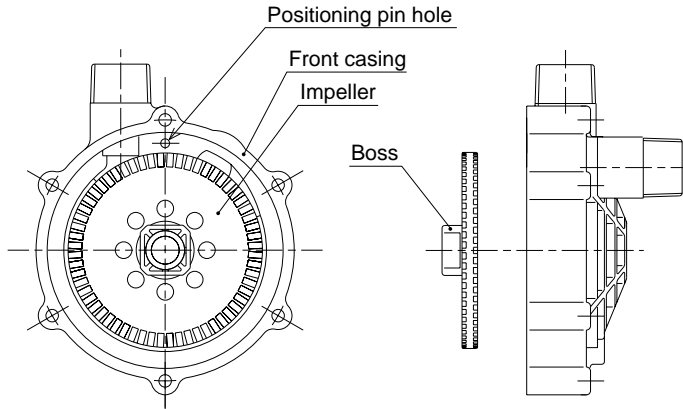

2) Insert positioning pin (11) into positioning pin hole of front casing (12). Mount rear plate (9) on front casing (12) positioning the rear plate (9) so that the pin (11) comes to pin hole of rear plate (9).

When rear plate (9) was correctly mounted on front casing (12), rear plate "B" surface comes approx. 5.5mm below the front casing "A" surface. Refer to illustration below.

Confirm that the positioning pin is correctly inserted into the rear plate. If the pin is inserted correctly, the rear plate does not move to the direction shown by arrow as below.

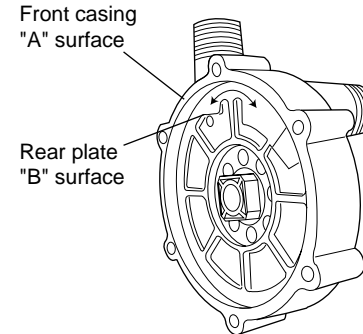

Note: For the above procedures 1) and 2), rear plate can be mounted easily if a round bar of 100mm dia. (approx. 5 cm long) is inserted into the bearing of front casing (12) to position impeller (10).

Maintenance

- 3) Apply a little bit of silicone grease to O ring (7) and mount it on front casing (12). Pay attention for O ring not to be twisted.

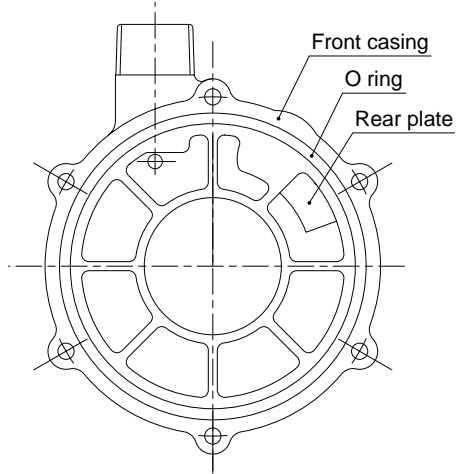

- 4) Mount magnet capsule (6) to front casing (12) by engaging spindle of magnet capsule with impeller (10).

- 5) Mount rear casing (5) to front casing (12). As shown on illustration below, push front casing strongly putting your weight on it so that front casing A surface and rear casing B surface become flat as shown on illustration below.

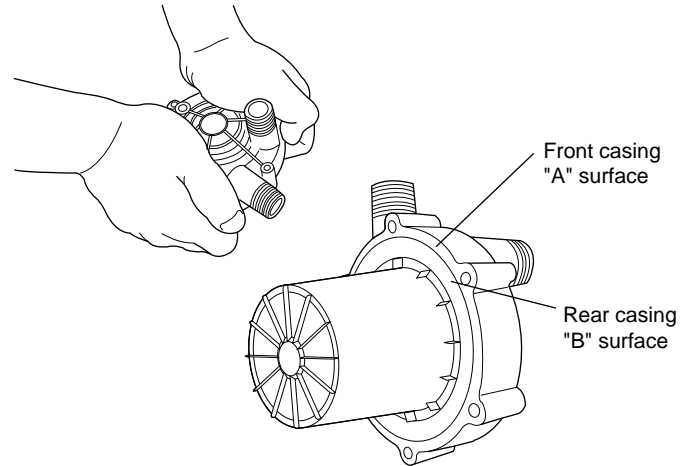

Maintenance

- 6) Paying attention to the position of three through holes of mounting plate, fix the unit of front casing to rear casing to mounting plate (8) with six screws (14) (with plate washers and spring washers).
Tightening torque : 0.7N·m

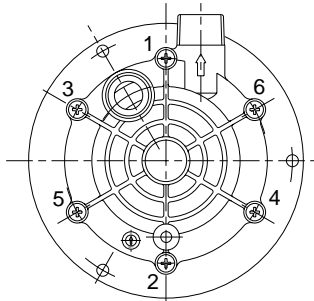

Caution : Tighten six screws in diagonal order as shown above evenly little by little and finally by specified tightening torque.

- 7) Mount assembled pump unit to motor (1) and tighten it by three screws (13).
(Tightening torque : 1.42 N·m)

Maintenance

5. Construction and parts names

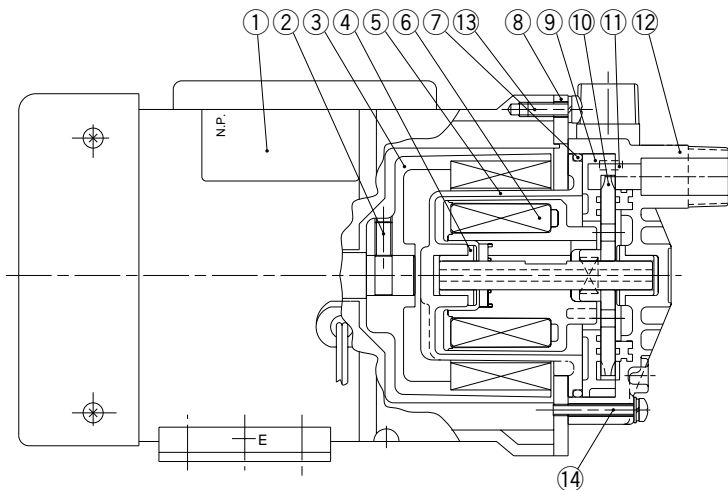

| No. | Parts name | Q'ty | Material | Remarks | No. | Parts name | Q'ty | Material | Remarks |
|-----|------------------------|------|-----------------------------------|---------|-----|-----------------|------|-----------------|-----------------------|
| 1 | Motor | 1 | | | 8 | Mounting plate | 1 | Aluminum alloy | |
| 2 | Hex. socket head screw | 1 | Steel | M6 × 12 | 9 | Rear plate | 1 | CFRPPS | |
| 3 | Drive magnet unit | 1 | Ferrite, Aluminum alloy | | 10 | Impeller | 1 | CFRPEEK | |
| 4 | Bearing | 2 | Carbon or Siliconized graphite | | 11 | Positioning pin | 1 | GFRPPS | |
| 5 | Rear casing | 1 | GFRPPS | | 12 | Front casing | 1 | GFRPPS | |
| 6 | Magnet capsule | 1 | GFRPPS, Ferrite, Alumina ceramics | | 13 | Screw | 3 | Stainless steel | M5 × 15 |
| 7 | O ring | 1 | EPDM | | 14 | Screw | 6 | Stainless steel | M4 × 30 (with PW, SW) |



()Country codes
IWAKI CO.,LTD. 6-6 Kanda-Sudacho 2-chome Chiyoda-ku Tokyo 101-8558 Japan
TEL:(81)3 3254 2935 FAX:3 3252 8892(<http://www.iwakipumps.jp>)

| | | | | | |
|---|------------------------|--------------------|--|-------------------------|---------------------|
| U.S.A. : IWAKI America Incorporated | TEL : (1)508 429 1440 | FAX : 508 429 1386 | Germany : IWAKI EUROPE GmbH | TEL : (49)2154 9254 0 | FAX : 2154 1028 |
| Australia : IWAKI Pumps Australia Pty. Ltd. | TEL : (61)2 9899 2411 | FAX : 2 9899 2421 | Italy : IWAKI Italia S.R.L. | TEL : (39)02 990 3931 | FAX : 02 990 42888 |
| Singapore : IWAKI Singapore Pte. Ltd. | TEL : (65)6316 2028 | FAX : 6316 3221 | Denmark : IWAKI Pumper A/S | TEL : (45)48 24 2345 | FAX : 48 24 2346 |
| Indonesia : IWAKI Singapore (Indonesia Branch) | TEL : (62)21 690 6606 | FAX : 21 690 6612 | Sweden : IWAKI Sverige AB | TEL : (46)8 511 72900 | FAX : 8 511 72922 |
| Malaysia : IWAKIm Sdn. Bhd. | TEL : (60)3 7803 8807 | FAX : 3 7803 4800 | Finland : IWAKI Suomi Oy | TEL : (358)9 2742714 | FAX : 9 2742715 |
| Taiwan : IWAKI Pumps Taiwan Co., Ltd. | TEL : (886)2 8227 6900 | FAX : 2 8227 6818 | Norway : IWAKI Norge AS | TEL : (47)66 81 16 60 | FAX : 66 81 16 61 |
| Thailand : IWAKI (Thailand) Co.,Ltd. | TEL : (66)2 322 2471 | FAX : 2 322 2477 | France : IWAKI France S.A. | TEL : (33)1 69 63 33 70 | FAX : 1 64 49 92 73 |
| Hong Kong : IWAKI Pumps Co., Ltd. | TEL : (852)2 607 1168 | FAX : 2 607 1000 | U.K. : IWAKI PUMPS (UK) LTD. | TEL : (44)1743 231363 | FAX : 1743 366507 |
| China : IWAKI Pumps (Guandong) Co., Ltd. | TEL : (86)750 380 9018 | FAX : 750 380 9078 | Switzerland : IWAKI (Schweiz) AG | TEL : (41)26 674 9300 | FAX : 26 674 9302 |
| China : GFTZ IWAKI Engineering & Trading (Guangzhou) | TEL : (86)20 8435 0603 | FAX : 20 8435 9181 | Austria : IWAKI (Austria) GmbH | TEL : (43)2236 33469 | FAX : 2236 33469 |
| China : IWAKI Pumps Co., Ltd. (Beijing) | TEL : (86)10 6442 7713 | FAX : 10 6442 7712 | Holland : IWAKI Holland B.V. | TEL : (31)297 241121 | FAX : 297 273902 |
| China : IWAKI Pumps (Shanghai) Co., Ltd. | TEL : (86)21 6272 7502 | FAX : 21 6272 6929 | Spain : IWAKI Iberica Pumps, S.A. | TEL : (34)943 630030 | FAX : 943 628799 |
| Philippines : IWAKI Chemical Pumps Philippines, Inc. | TEL : (63)2 888 0245 | FAX : 2 843 3096 | Belgium : IWAKI Belgium n.v. | TEL : (32)1367 0200 | FAX : 1367 2030 |
| Korea : IWAKI Korea Co.,Ltd. | TEL : (82)2 3474 0523 | FAX : 2 3474 0221 | | | |